

Instructions for Installation and Operation

Unfiltered SCR Brushless DC Motor Speed Control

Model 3910



SPECIFICATIONS

Product Type	ABL-3910C
Input Voltage	115 VAC \pm 10%, 50/60 Hz (Single Phase)
Input Current	6 Amps rms
Output Voltage	0 to 90 VDC
Continuous Output Current	3.0 Amps
Peak Output Current	6.0 Amps
Ambient Temperature	0 to 50° C (Maximum)
Control Hp Range	Up to 3/8 Hp
Control Speed Range	Up to 30:1
Acceleration Time Range	0.2 to 10 seconds (0 to full speed)



www.bodine-electric.com



IMPORTANT

Read this manual completely and carefully. Pay special attention to all warnings, cautions, and safety rules. Failure to follow the instructions could produce safety hazards which could injure personnel or damage the control, motor, or other equipment. If you have any doubts about how to connect the control or motor, refer to the detailed sections of this manual.

QUICK REFERENCE

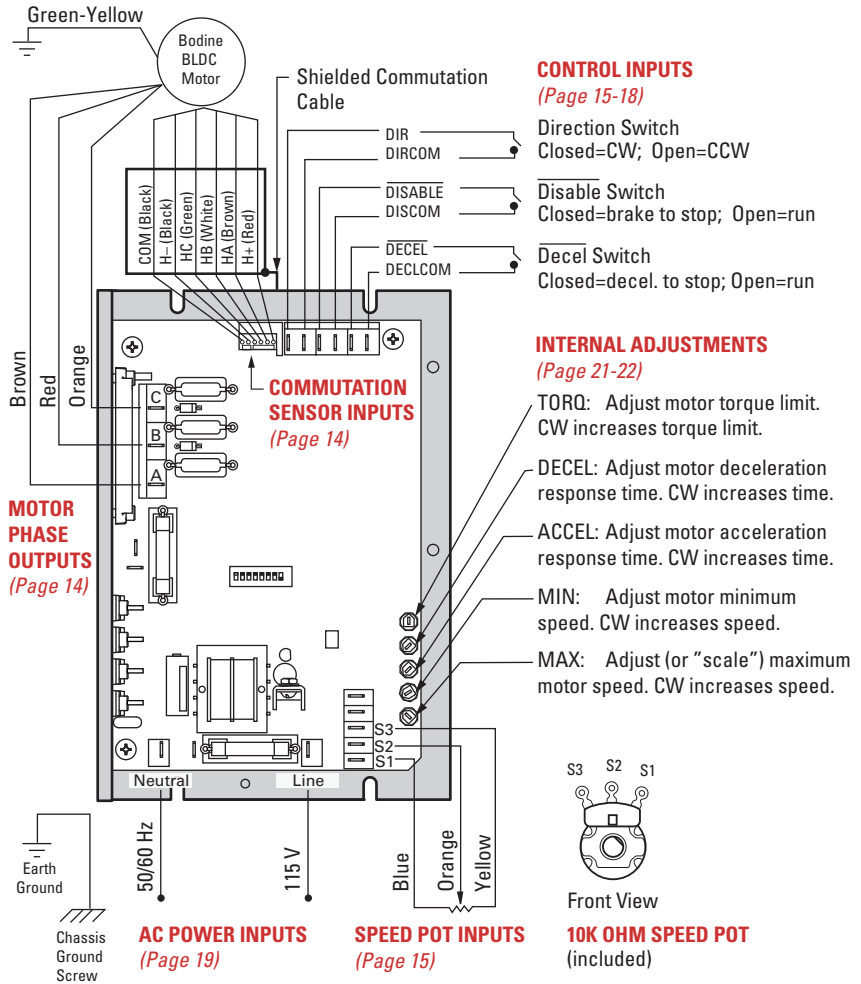

Figure 1 – Quick Reference Diagram

TABLE OF CONTENTS

QUICK REFERENCE INSTALLATION	2
GENERAL INFORMATION	4
CONTROL DESCRIPTION AND FEATURES	5
SPECIFICATIONS	6
IMPORTANT SAFETY PRECAUTIONS	6
INSTALLATION INSTRUCTIONS	10
Mounting the Control	10
Electrical Connections	10
Cable Assembly	11
Horsepower (DIP) Switch Settings	12
Commutation Sensor Connections	14
Motor Phase Connections	14
Fuse Installation	14
Manual Control Input Connections	15
Electronic Control Input Connections	17
Tachometer Output	18
AC Power Connections	19
Power Input	19
OPERATING INSTRUCTIONS	20
Preliminary Checks	20
Operating the Control	20
Internal Adjustments	21
TROUBLESHOOTING	23
WARRANTY	26

FIGURES

Figure 1 – Quick Reference Connection Diagram	2
Figure 2 – Heatsink Orientation	11
Figure 3 – Model 3983 Cable Assembly	11
Figure 4 – Control Circuit Board Detail	13
Figure 5 – DIP Switch 7 and 8 Speed Range Settings	13
Figure 6 – Horsepower (DIP Switch) Settings and Fuse Selection Chart	13
Figure 7 – Manual Speed Potentiometer/Interface Details	15
Figure 8 – Manual Switch and Relay Control Inputs	16
Figure 9 – Connection to Model 3984 Isolation Interface	18
Figure 10 – Tachometer Output	18
Figure 11 – Speed/Torque Curve Showing Reduced Torque at Low Speeds	22

GENERAL INFORMATION

Congratulations!

And thank you for selecting a Bodine Type ABL-3900 Series Brushless DC Motor Control. Your new control will provide the same excellent performance and reliability that have been a Bodine tradition since 1905. Bodine Electric Company takes pride in the quality of its products and in satisfying its customers. Every effort has been made to provide you with a product free of defects in design, workmanship, and materials. In order for us to maintain our tradition of quality, please report any cases of unsatisfactory service or products to Bodine Electric Company promptly.

About This Manual

This manual contains the basic information needed to install and operate a Bodine Model ABL-3910C Brushless DC Motor Control. It is organized in a systematic, step-by-step fashion so that the system may be set up safely in the shortest possible time. It does not profess to cover all details or variations in equipment, nor to provide for every possible contingency associated with installation, operation, or maintenance—and no warranty of fitness for purpose is expressed or implied. Should further information be desired or should particular problems arise which are not covered sufficiently for the user's purpose, the matter should be referred to the Bodine Electric Company.

The issuance of this manual does not confer to the recipient any license to manufacture under any patents owned or controlled by the Bodine Electric Company.

Safety Standards

Bodine products are designed and manufactured to comply to applicable safety standards and in particular to those issued by ANSI (American National Standards Institute), NEMA (National Electrical Manufacturers Association), U.L. (Underwriters Laboratories, Inc.), and CSA (Canadian Standards Association).

Bodine equipment “recognized by U.L., Inc.” are either labeled with the UR or cURus marks. In addition, products that are CSA certified are identified by the CSA mark. If you need specific information regarding the third-party approval status of Bodine products, contact the nearest Bodine representative, or the home office.



CONTROL DESCRIPTION AND FEATURES

The ABL-3910C Brushless DC Motor Control is a chassis style control, designed to be mounted into a separate control enclosure supplied by the user. The control operates from a nominal 115 VAC, 50/60 Hz. power source. The control provides electronic commutation and phase current switching needed to operate brushless DC motors. DIP switch selectable current limit settings allow the control to be used with a wide range of fractional horsepower motors and gearmotors.

The ABL-3910C provides a 90 Volt unfiltered DC output. The control allows motor speed to be manually or electronically controlled.

Motor direction of rotation, disabling, and soft starts and stops can be controlled with manual switch inputs or by logic control. Since the control's signal common is not at ground potential, interface circuitry is required to isolate logic signals from the control. Trim potentiometers on the control board allow additional fine tuning of minimum and maximum speed settings, torque, acceleration and deceleration times. A built-in "Smart Reverse"TM circuit prevents plug reversing by disabling the motor until it coasts to a stop before changing its direction. A built-in shutdown circuit disables the control during overvoltage, under-voltage, or invalid commutation sensor state conditions.

Specific Bodine motor sizes which can be used with these controls are listed in the Chart in Figure 6.

Accessory Items

- Model 3983 Connection Cable Assembly — one end equipped with circular connector; other end equipped with quick disconnects for phase leads and connector for commutator leads. Length: 6ft. (See Figure 3)
- Model 3982 Extension Cable — extends cable between motor and control by six feet. Both ends equipped with circular connectors for easy connection between Model 3983 Cable and motor. Length: 6ft.
- Model 3984 Isolated Interface Module (See page 18.)

Parameter	Specification
Product Type	ABL-3910C
Model Number	3910
Input Voltage:	115 VAC \pm 10%, 50/60 Hz (Single Phase)
Input Current	6 Amps rms
Output Voltage	0 to 90 VDC
Output Voltage	0 to 90 VDC
Continuous Output Current	3.0 Amps
Peak Output Current	6.0 Amps
Ambient Temperature:	0 to 50° C (Maximum)
Control HP Range:	Up to 3/8 Hp
Control Speed Range:	Up to 30:1
Control Speed Regulation:	Less than 1% of rated (Typical)
Line Voltage Compensation:	Negligible speed change with changes in line voltage
Acceleration Time Range:	0.2 to 10 seconds (0 to full speed)
Dimensions:	in: 5.5 W x 8.0 D x 1.8 H
	cm: 14.0 W x 20.4 D x 4.6 H
Net Weight:	2.0 lbs. (0.81 kg.)

IMPORTANT SAFETY PRECAUTIONS

The following safety precautions must be observed during all phases of installation, operation, service, and repair of this motor control product. Failure to comply with these precautions or with specific warnings elsewhere in this manual violates safety standards of design, manufacture and intended use of the products. Bodine Electric Company assumes no liability for the customer's failure to comply with safety requirements and practices.

The use of electric motors and gearmotors, like that of all utilization of concentrated power, is potentially hazardous. The degree of hazard can be greatly reduced by proper design, selection, installation, and use, but all hazards cannot be completely eliminated. The reduction of hazards is a joint responsibility between the user, the manufacturer of the driven or driving equipment and the manufacturer of the control or motor.

The user should refer to Publication No. ANSI C5.1/NEMA MG 2, *Safety Standard for Construction and Guide for Selection, Installation and Use of Electric Motors and Generators*. Available from:

National Electrical Manufacturers Association
www.nema.org

Warnings (such as the example below) highlight procedures which present potential danger to people. **Cautions** highlight possible danger to equipment. Both are used throughout this manual. Warnings and Cautions must always be followed.

WARNING

Dangerous voltages may be present in the electronic control and motor. These voltages could cause serious injury or death. Use extreme caution during handling, testing, and adjusting. Properly guard the electronic control and motor to prevent accidental contact by all persons. The chance of explosions, fires, or electric shocks can be reduced with thermal and over-current protection, proper grounding, enclosure selection, and good maintenance. The following safety considerations are not intended to be all-inclusive. Specific references throughout this manual should also be consulted.

CAUTION

These controls are designed to provide optimum performance when used with Bodine Electric Company motors. They should not be used with other manufacturer's motors without first contacting the Bodine Electric Company. Failure to contact Bodine in advance could cause damage to the control or the motor.

Inspecting the Control

Check the items you received against your purchase order. Carefully examine the control (and any optional kits or parts) for shipping damage. Parts errors should be reported to Bodine. Shipping damage claims should be made to the freight carrier.

Before installation, review the application to confirm that the proper motor and control have been selected. This should be done after reading this manual and all applicable safety standards. If in doubt, contact your Bodine representative, or the home office if there is no representative in your area. Although Bodine Electric Company assists its customers in selecting motors and controls for specific applications, determination of fitness for purpose or use is solely the customer's responsibility.

Normal Operating Conditions

Unless otherwise agreed to by Bodine, all control nameplate ratings are based on the following normal operating conditions. Consult Bodine Electric Company if variations beyond these limits are anticipated.

1. *Continuous Duty*: without frequent reversals or starts and stops.
2. *Maximum Ambient Temperature*: 50° C (122° F) for chassis controls; 40° C (104° F) for all encased controls.
3. *Voltage*: Within 10% of nameplate rating.
4. *Frequency*: Within 5% of nameplate rating.
5. *Combined Variation of Voltage and Frequency*: Within a total of 10% providing frequency variation does not exceed 5%.

Grounding

Both electronic controls and motors must be securely mounted and adequately grounded. Failure to ground properly may cause serious injury to personnel.

Fusing

Both the control input and output are fused. When fuses are replaced, they must always conform to the values and ratings specified on the control's nameplate or in the fuse chart located in Figure 5.

Live Circuitry

Open-type electronics should be properly guarded or enclosed to prevent accidental human contact with live circuitry. No work should be performed on or close to the control or motor while the control is connected to the AC line. If an AC line switch is used, it should be a Double Pole Single Throw (DPST), so that both sides of the AC line are disconnected.

Environment

Open controls or controls in ventilated enclosures may emit flame during failure. Bodine's totally enclosed products are not explosion-proof, and Bodine does not offer an explosion-proof motor, gearmotor, or control for hazardous locations (e.g. in an environment of flammable or explosive gas, vapor, or dust). Bodine recommends use of only approved explosion-proof products in hazardous locations. Exceptions are allowed by the National Electric Code (NEC), but NEC and NEMA safety standards should be studied thoroughly before exercising this option. Moisture increases the electrical shock hazard of electrical insulation. Therefore, open-type or unsealed controls not specifically designed for such use should be protected from contact with liquids or moisture.

Ventilated Products

Open ventilated products are suitable for clean, dry locations where cooling air is not restricted. Do not insert anything into a product's ventilation openings.

Servicing

Emergency field repairs must be made only by authorized Bodine service representatives. Repairs made by persons not authorized by the Bodine Electric Company will void the warranty. Field repairs must be limited to replacing an entire printed circuit board assembly. Because of the danger of introducing safety hazards, do not install substitute parts or perform any unauthorized modifications to electronic PC boards, components or motors. To ensure continued compliance with the design specifications and safety standards, the electronic control or motor should be returned to Bodine Electric Company or an Authorized Service Center for servicing.

WARNING

To avoid injury because of unsuspected mechanical motion, always disconnect the 115 VAC power to the control before performing any service procedures on the motor, control, or driven equipment.

INSTALLATION INSTRUCTIONS

IMPORTANT

This control should only be installed by a qualified technician, electrician or electrical maintenance person familiar with its operation and associated hazards. The National Electrical Code (NEC), local electrical and safety codes, and when applicable, the Occupational Safety and Health Act (OSHA) should be observed to reduce hazards to personnel and property.

The user must provide a proper enclosure for chassis type controls. Circuitry is not at ground potential. Do not perform work on or near the control while it is connected to the AC line.

CAUTION

Exposed circuit boards should be protected from electrostatic discharge. The control board uses CMOS circuitry. Static discharge into the control board must be avoided to prevent component damage.

Mounting the Control

Detailed mounting dimensions and CAD drawings are available online. The preferred mounting orientation for the control is vertical, but it can be mounted in non-vertical orientation as long as the ambient temperature does not exceed 50°C. Use the slots on either the narrow or wide surfaces of the heat sink. This arrangement provides optimum air flow around the control. Refer to Figure 2.

Electrical Connections

Read the following instructions as well as all of the applicable safety recommendations, before making any electrical connections between the control, motor, or motion control electronics.

WARNING

The 115 VAC power line to the control should be the very last connection made. Disconnect the power line before making any other electrical connections.

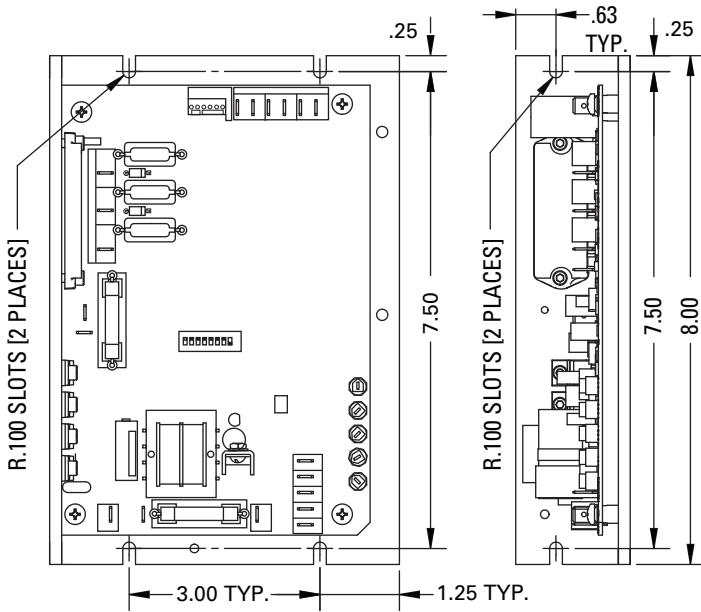

Figure 2– Heatsink preferred mounting orientation

Cable Assembly

The Model 3983 Cable Assembly, shown in Figure 3, is designed to simplify the electrical connections to the ABL-3910C Control. One end of the cable which connects to the motor is terminated with a circular type connector. The other end which connects to the control has a six-pin rectangular connector, three individual motor phase leads with quick disconnects, and an earth ground lead.

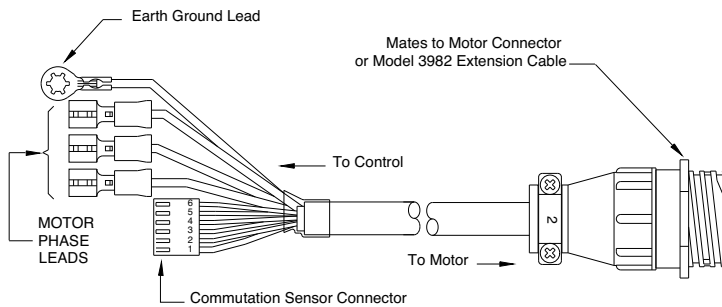

Figure 3 – Model 3983 Cable Assembly

WARNING

The shield common is at a dangerous potential above ground and presents a voltage hazard. Contact with the shield could cause serious injury or death. If a non-Bodine cable is used or if a special cable is fabricated, care should be taken to insulate all exposed shield to avoid serious injury. The shield should only be connected to the COM terminal on the Commutation Sensor Input Connector at the control. No other shield connection should be made. The user must provide a proper enclosure for chassis type controls. Circuitry is not at ground potential. Do not perform work on or near the control while it is connected to the AC line.

CAUTION

Only copper wire with a minimum 60° C rated insulation is recommended if Bodine cable assemblies are not used. If your control is equipped with a terminal block, it will accept leads up to 14 gauge. (18 gauge is the smallest recommended size.)

Horsepower (DIP Switch) Settings

Figure 5 shows a Horsepower Select switch on the main control board which contains eight switch levers numbered 1 through 8. The chart in Figure 6 shows the proper DIP switch settings for various Bodine motor types.

Determine the first four digits of the motor's type number from the nameplate. Find the same four digits in the chart in Figure 6 to determine the proper settings of the DIP switches. An insulated alignment tool should be used to adjust the switch settings.

Motor Commutation Phasing (60° standard)

All standard (stock) brushless DC motors and gearmotors manufactured by Bodine Electric Company are designed for 60° commutation. The factory setting for our BLDC speed controls is also for 60° commutation. It is possible to configure our BLDC stock controls to operate non-Bodine BLDC motors and gearmotors with 120° commutation angle. To change the sensor phasing output on our stock controls for 120° commutated gearmotors or motors, set DIP switch number 6 to the "Off" position. Please note that further application details must be considered to properly match a non-Bodine BLDC motor with one of our stock BLDC controls. To avoid damage or system performance issues, please consult our Technical Support staff at 773-478-3515 or via E-mail: info@bodine-electric.com.

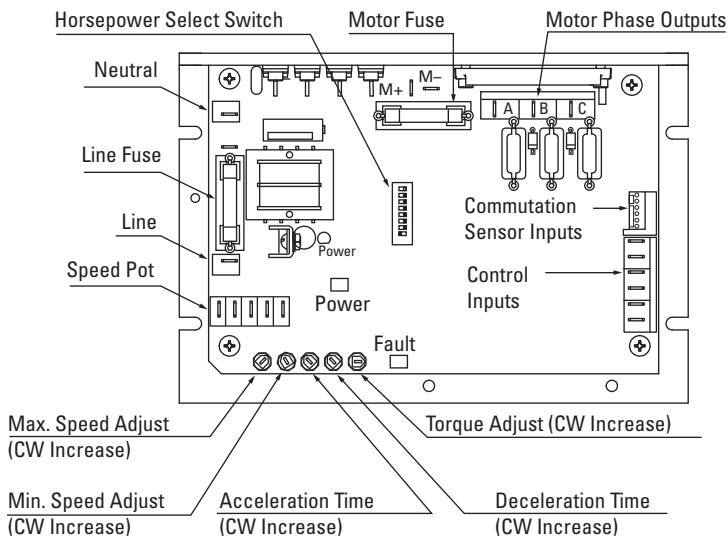

Figure 4 – Control Circuit Board Detail

Typical MAX Motor Speeds with 10 K Speed Pot						
	DIP Switch 7	DIP Switch 8	CCW MAX Pot	Calibrated MAX Pot	CW MAX Pot ¹	T-Out Pulse Width (µS)
Factory Setting	ON	ON	1000	1700	2000	1200
	ON	OFF	1000	1700	2000	1200
	OFF	ON	1500	2500	3000	800
	OFF	OFF	1500	2500	3000	800

1. Max. Speed obtainable is dependent on motor winding (voltage, speed rating, resistance), line voltage and load conditions.

Figure 5 – DIP Switch 7 and 8 Speed Range Settings

Control Model Number	Motor or Gearmotor Type	Hp At full Speed with Unfiltered Control	Full Speed with Unfiltered Control	DIP Switch Levers in the "On" Position	Line Fuse (F1)	Motor Fuse (F2)	AC rms Input Current
ABL-3910C	22B2...	1/32	1725	2,6,7	ABC-8	MDA 6/10	0.7
	22B3...	1/22		1,2,6,7		MDA 8/10	0.9
	22B4...	1/14		1,3,6,7		MDA 1-1/4	1.3
	34B3...	1/11		1,2,3,6,7		MDA 1-1/2	1.7
	34B4...	1/9		2,4,6,7		MDA 2	2.2
	34B6...	1/6		1,5,6,7		MDA 3	3.1

Figure 6– Horsepower (DIP Switch) Settings and Fuse Selection Chart

Commutation Sensor Connections

The commutation sensor leads are prewired in the Model 3983 cable assembly and terminated in a six-pin connector (Figure 3). There is a corresponding “Commutation” connector on the main control board (Figure 4). Mate the polarized cable connector to the “Commutation” connector on the control board. The connectors can only mate one way.

Motor Phase Connections:

The ABL-3910C unfiltered control utilizes quick connect terminals on the main control board. Refer to Figure 4.

Locate the Motor Phase Outputs labeled “A,” “B,” and “C” on the main control board. Connect the phase leads as follows:

- Brown to Motor Phase Output “A”
- Red to Motor Phase Output “B”
- Orange to Motor Phase Output “C”

Fuse Installation

The control input and output are fused. The line input fuse has been installed at the factory. The control output or “Motor Fuse” must be selected based on the size of the motor.

Line Fuse

The location of line fuse (F1) is shown in Figure 4. It should always be replaced with a fuse of the same type and rating. Its rating can be determined by referring to the chart in Figure 6.

Motor Fuse

The location of motor fuse (F2) is shown in Figure 4. The fuse rating will vary with the size of the motor used. To determine the proper fuse rating, locate the first four digits of your motor’s type number on the motor nameplate. Find the same four digits in the chart in Figure 6 to determine the fuse size. The ABL-3910C is supplied without motor fuses.

CAUTION

The control board signal common is not at ground potential. Any external signal or equipment connected to the control must be electrically isolated from ground (e.g., relay or optically isolated). Non-isolated signals will damage the control and/or associated external equipment.

Manual Control Input Connections

Motor speed, braking, direction of rotation and deceleration can be controlled manually or electronically. Refer to the following procedures for connecting control inputs.

Manual Speed Control

A Manual Speed Potentiometer Kit for controlling motor speed is included with the control. The kit contains a 10K Ohm potentiometer, mounting hardware, and three 24-inch long leads terminated on one end with 1/4 inch quick connects.

To connect the speed potentiometer, proceed as follows:

1. Solder the three leads to the potentiometer as shown in Figure 1.
2. Mount the potentiometer in the desired location.
3. Connect the speed pot to the control board terminals as follows:
4. follows:
 - Blue to Terminal "S1"
 - Orange to Terminal "S2"
 - Yellow to Terminal "S3"

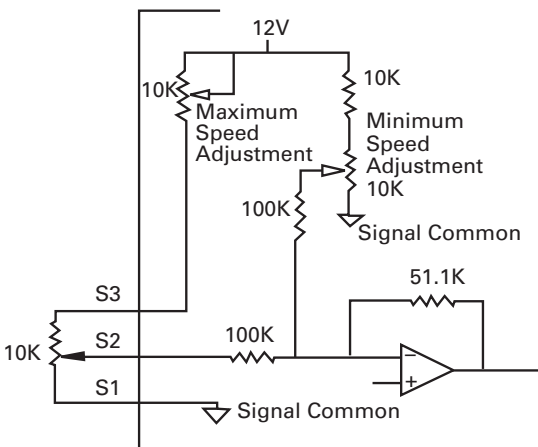

Figure 7– Manual Speed Potentiometer/Interface Details

NOTE: The DISCOM, DIRCOM, DECLCOM, S1, and COM terminals on the control board are all connected in common.

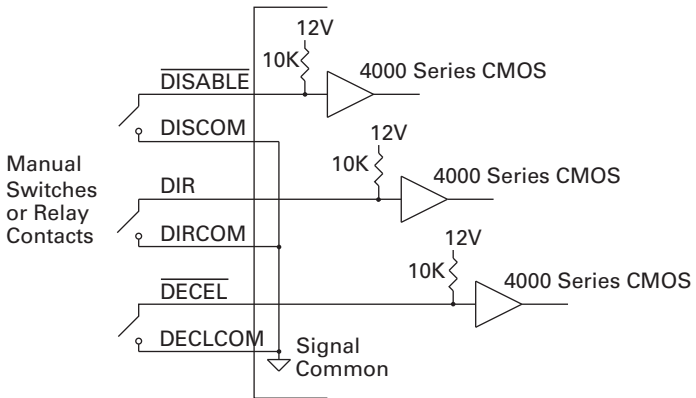

Figure 8 – Manual Switch and Relay Control Inputs.

Manual Disable, Direction of Rotation, and Deceleration:

Mechanical switches or relays can be used to switch the control inputs. Figure 8 shows a schematic representation of manual or relay switched inputs.

The following chart lists the control functions relative to the state of the mechanical switches or relay.

Switch	Closed	Open
$\overline{\text{DISABLE}}^1$	Stop	Run
$\overline{\text{DIR}}^2$	CW ⁴	CCW ⁴
$\overline{\text{DECEL}}^3$	Decelerate	Accelerate

1. The ABL-3910C does not include a braking module. When the $\overline{\text{DISABLE}}$ switch is closed, the motor will simply coast to a stop.
2. The ABL-3910C includes a “Smart Reverse Circuit” which prevents plug reversing when the DIRection switch is opened or closed. The motor will coast to a stop before changing direction.
3. The DECEL switch controls soft stops and starts. The degree of acceleration and deceleration can be varied with the trim potentiometers on the control board. See Page 22.
4. The output shafts of gearmotors with odd number of stages (Bodine type designations ending with W3, E1, or E3) will rotate in the opposite direction.

Electronic Control Input Connections

Optional Interface Boards are available from Bodine and other manufacturers. They provide electrical isolation between the input signal and the brushless DC motor control circuitry, and are recommended for motion control applications requiring electronic control of motor speed, rotational direction, deceleration, and disable.

Electronic Speed Control

Motor speed can be controlled with a 0 to +10 VDC isolated signal with 0.1 mA current capability in lieu of the manual speed potentiometer. This speed control input should be connected to terminal S2 on the control board. The common side of the signal must also be isolated and connected to terminal S1 on the main control board.

Logic Signal Control of Disable, Direction of Rotation, and Deceleration:

Motor disable, direction of rotation and deceleration can be controlled using optically isolated logic signals from a programmable controller, personal computer, or other electronics.

WARNING

Never rely on logic circuitry as a means of disabling the motor or control. To prevent unsuspected mechanical motion and potential injury, the 115 VAC power should always be disconnected whenever logic circuits or the driven equipment are serviced.

Exercise extreme caution when using Programmable Logic Controllers (PLCs). Although some may claim to have optically isolated output modules, their output commons may be connected to other circuitry either within or connected to the PLC. In such cases, the PLC outputs should be isolated from the ABL-3910 Series control board, by a relay or by an electronic isolation module, to prevent damage to the PLC or the ABL-3910 Series control.

If a Programmable Controller with a relay output module is not available, AC or DC outputs from the PLC can be used to drive separate relay coils. See PLC user's manual for application information. See Figure 9 to determine how to connect relay contacts to the ABL-3910C.

Signal Isolation Using a Bodine Model 3984 Interface Module:

Follow the installation instructions provided with the module to isolate the input signals between the control electronics and the ABL-3910 Series Control. See Figure 9 for connections.

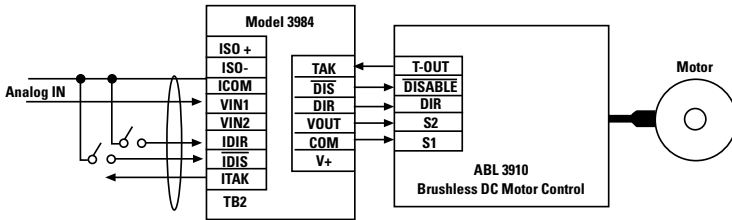

Figure 9 – Connection to Model 3984 Isolation Interface

Tachometer Output

When used with the Bodine ABL-3910 Brushless DC Motor Controls, the Model 3984 module provides a digital tachometer output at the ITAK terminal for monitoring motor speed. The output pulse levels are low to high to low. The typical pulse width is 0.8 msec. for the ABL-3910. Twelve pulses correspond to one motor revolution. The ITAK output provides an unterminated open collector output. A pull-up resistor or another logic device is required for measuring the output. See Figure 10 for assistance in interfacing the ITAK output.

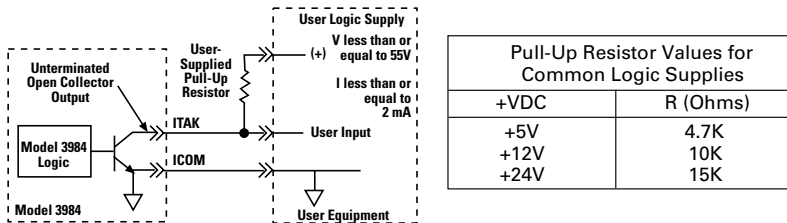

Figure 10 – Tachometer output

AC Power Connections

Power should always be the last connection made during installation and the first item to be disconnected before servicing.

WARNING

The control and motor must be securely and adequately connected to earth ground as indicated below. Failure to ground properly may result in serious injury.

Power Input

The ABL-3910C unfiltered control utilizes quick connect terminals. Refer to Figure 4.

Locate the quick connect terminals labeled “L” and “N” on the main control board near the line fuse. Connect AC power as follows:

1. Hot side of 115 VAC line to Terminal “L”.
2. Neutral side of 115 VAC line to Terminal “N”.
3. A green screw and cup washer are provided on the short surface of the heat sink for chassis ground connections.

OPERATING INSTRUCTIONS

WARNING

Explosions, fires, or electric shock hazards can be reduced through thermal and over-current protection, good maintenance, proper grounding, and enclosure selection. Review safety considerations outlined in "Safety Precautions" and "Installing the Control."

Preliminary Checks

1. Before starting the control, check all fuses, connections, and adjustments such as horsepower DIP switch settings.
2. Proper consideration should be given to all rotating members. Before starting, be sure keys, pulleys, etc. are securely fastened. Proper guards should be provided to prevent hazards to personnel while the equipment is rotating.
3. Mechanical considerations such as proper mounting and alignment of products, and safe loads on shafts and gears should be reviewed. Do not depend upon gear friction to hold loads.
4. The motor or gearmotor should be securely mounted (because of possible reaction torque). Test the motor/gearmotor unloaded to be certain that proper connections have been made.

Operating the Control

WARNING

The 115 VAC line to the driver should be switched off before starting.

1. Turn input power OFF and set the speed potentiometer to ZERO (fully counterclockwise). If a Disable switch is used, close the switch. If a Direction switch is used set it for the desired direction of rotation. If a Deceleration switch is used, open the switch. See Figure 8.
2. Connect the 115 VAC power line to the external power source. Then turn on the 115 VAC input power to the control.
3. Open the Disable switch, if used.
4. Turn speed potentiometer knob until motor rotates. Then adjust the potentiometer to achieve the desired speed. If you wish to reduce the torque level, refer to Internal Adjustments on next page.
5. If the motor does not operate, first observe if the green POWER light and red FAULT light are on (refer to Figure 4 for location). Then disconnect the AC power to the control and check all connections and fuses. If a fuse is blown and the motor is not locked (stalled) or overloaded, do not replace

the fuse. The control may be damaged. Refer to Troubleshooting and follow instructions. If the motor is overloaded, reduce the load and replace blown fuses with those of the proper type and rating as specified in Figure 6.

Internal Adjustments

Your control has been factory-adjusted for the following settings:

Minimum speed: 0 RPM

Maximum speed: 1725 RPM

Acceleration: 2 seconds

Deceleration: 2 seconds

Torque: 200% of rated (based on proper DIP switch settings)

Refer to Figure 4 for the trim potentiometer locations and approximate initial settings. If you need to readjust the control for your specific applications, proceed as follows:.

WARNING

Use a non-metallic or insulated adjustment tool (such as a television alignment tool) for internal adjustments. Circuit components are not at ground potential and accidental short circuiting and shock hazard may occur with conducting tools. Adjustment should be made only by qualified service personnel.

Minimum and Maximum Speed

The MIN and MAX trim potentiometers have been factory calibrated. The lowest MIN trim potentiometer setting (fully counterclockwise) corresponds to 0 RPM and the highest MIN setting (fully clockwise) corresponds to approximately 30% of rated speed.

The lowest MAX trim potentiometer setting (fully counterclockwise) corresponds to 60% of rated speed and the highest MAX trim potentiometer setting (fully clockwise) corresponds to approximately 120% of rated speed. Refer to Figure 4 for trim potentiometer location and settings. Adjustment of the MIN and MAX trim potentiometers may have to be repeated several times to arrive at the desired speeds

NOTE: Increasing the MIN potentiometer setting will increase the maximum speed beyond nameplate speed. The MAX trim potentiometer will need to be readjusted.

Torque (Current) Limiting Adjustment:

The TORQ trim potentiometer (Figure 4) has been calibrated so that the motor will never see more than 200 to 250% of its rated current input if the DIP switches are set properly. The motor's torque output can be reduced to zero or stall torque. Turn the TORQ trim potentiometer counterclockwise to decrease the torque and clockwise to increase the torque.

NOTE: For a given setting of the TORQ potentiometer, the output torque at speeds below 100 RPM will be less than at higher speeds. Refer to Figure 11.

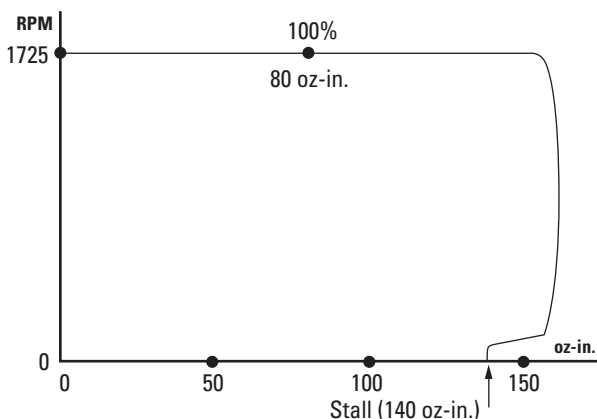

Figure 11 –Speed/Torque Curve showing decreased torque at lower speeds

Acceleration Adjustment:

Adjusting the ACCEL trim potentiometer (See Figure 4) counterclockwise decreases the motor's acceleration time down to a minimum of approximately 0.2 seconds. A clockwise adjustment increases the rate up to a maximum of approximately 10 seconds.

Deceleration Adjustment:

Adjusting the DECEL trim potentiometer (See Figure 4) counterclockwise decreases the motor's deceleration time down to a minimum of approximately 0.2 seconds. A clockwise adjustment increases the rate up to a maximum of approximately 10 seconds.

TROUBLESHOOTING

WARNING

Disconnect the control from the power source before working on the control, motor, or driven equipment.

Your control should not require maintenance under normal conditions. If you encounter a problem, read all applicable instruction literature provided with this control and accessories, and double-check the wiring. The charts on the following pages also provide assistance in troubleshooting those problems which usually occur during normal installation and operation.

If the problem persists, contact your source of purchase and describe the problem in detail. Include all the nameplate data. Do not disassemble the product unless authorized by Bodine Electric Company. Performing repairs not authorized by Bodine Electric Company or removing screws will void the Warranty.

SYMPTOM	PROBABLE CAUSE	CORRECTIVE ACTION
CONTROL BLOWS LINE FUSE	Control or motor connected to or shorted to earth ground	Check for shorts and repair control and/or motor as required.
	Phase leads wiring incorrect	Correct wiring.
	Damaged control Components	Contact Bodine Electric Company.
MOTOR WILL NOT START AND POWER LIGHT IS OFF	Open line fuse	Replace fuse. Refer to page 14 for proper value.
	Open line switch	Close the line switch.
MOTOR WILL NOT START AND POWER LIGHT IS ON	Motor overloaded	Correct load or choose larger motor.
	TORQ trim pot is out of adjustment	Visually check setting (Figure 4). Adjust TORQ trim pot, page 22.

SYMPTOM	PROBABLE CAUSE	CORRECTIVE ACTION
MOTOR WILL NOT START AND POWER LIGHT IS ON (continued)	Open motor fuse	Replace fuse. Refer to Figure 6 for proper values.
	Speed potentiometer set to zero	Increase speed potentiometer setting.
	Closed $\overline{\text{DISABLE}}$ switch	Open $\overline{\text{DISABLE}}$ switch and restart.
	Closed $\overline{\text{DECEL}}$ switch	Open the $\overline{\text{DECEL}}$ switch.
	Electrical noise on $\overline{\text{DISABLE}}$ and/or $\overline{\text{DECEL}}$ input	Use shielded cable.
	Damaged motor	Repair or replace motor.
MOTOR WILL NOT START AND FAULT LIGHT IS ON	Mistake in motor commutation sensor inputs	Correct wiring.
	Electric noise on commutation sensor inputs	Use shielded cable.
	Damaged motor	Repair or replace motor.
MOTOR WILL NOT COME UP TO SPEED	MAX trim pot set too low	Adjust trim pot, page 21.
	Speed potentiometer set to low	Increase speed potentiometer.
	Motor overloaded	Reexamine the load parameters.
	TORQ trim pot is out of adjustment	Visually check settings (Figure 4). Adjust TORQ trim pot, page 22.
	Wrong horsepower setting	Check DIP switch setting, page 13.
	Damaged component on the control board	Contact Bodine Electric Company
MOTOR SPEED IS UNSTABLE OR PULSATES	Input signal too low	Increase input signal or scale VOUT using MAX trim potentiometer, page 18.

SYMPTOM	PROBABLE CAUSE	CORRECTIVE ACTION
MOTOR SPEED IS UNSTABLE OR PULSATES	Wrong horsepower setting	Check DIP switch setting, page 13.
	Motor and load not correctly aligned	Perform alignment.
	Speed potentiometer set too low	Increase speed potentiometer setting.
	Damaged motor	Repair or replace motor
MOTOR WILL NOT MAINTAIN SPEED UNDER LOAD	Wrong horsepower setting	Check DIP switch setting, page 13.
	TORQ trim pot is out of adjustment	Visually check setting (Figure 4). Adjust TORQ trim pot, page 22.
	Motor overloaded	Reexamine the load parameters.
MOTOR WILL NOT STOP WITH SPEED POT ADJUSTED AT ZERO	MIN trim potentiometer is set too high	Turn the MIN trim pot CCW until motor stops.
	Open connection on speed potentiometer	Check S1, S2, S3 connections.
	Defective speed potentiometer	Replace the potentiometer.
Note: The Disable input should be used when the motor is expected to remain stopped.		
NO SPEED ADJUSTMENT	Defective speed potentiometer	Replace the potentiometer.
	Open connection on speed potentiometer	Check S1, S2, S3 connections.

BODINE LIMITED WARRANTY

The Bodine Electric Company warrants all products it manufactures to be free of defects in workmanship and materials when applied in accordance with nameplate specifications. Bodine motors and gearmotors purchased with and used only with appropriately applied Bodine controls are covered by this warranty for a period of 24 months from the date of purchase or 30 months from date of manufacture, whichever comes first. Bodine motors and gearmotors used with non-Bodine controls and Bodine controls used with non-Bodine motors and gearmotors are covered by a 12 month warranty period. The Bodine Electric Company will repair, replace, or refund at its option, any of its products which has been found to be defective and within the warranty period, provided that the product is shipped freight prepaid, with previous authorization, to Bodine or to a Bodine Authorized Service Center. Bodine is not responsible for removal, installation, or any other incidental expenses incurred in shipping the products to or from Bodine. This warranty is in lieu of any other expressed or implied warranty – including, but not limited to, any implied warranties of merchantability and/or fitness for a particular use. Bodine’s liability under this warranty shall be limited to repair or replacement of the Bodine product and Bodine shall not be liable, under any circumstances, for any consequential, incidental or indirect damages or expenses associated with the warranted products. Proof of purchase of motor or gearmotor and matching control as a system must be provided with any claim.

Control Type _____ **Serial No.** _____

Date of Purchase _____ **Place of Purchase** _____

NOTES

Bodine offers over 1,000 standard gearmotors, motors and system-matched speed controls.



**Visit www.bodine-electric.com
for all your motion control needs.**

Bodine offers the widest selection of variable-speed AC, permanent magnet DC and brushless DC fractional horsepower gearmotors and motors in the industry. For complete specifications, 3D CAD drawings, or to order online, visit bodine-electric.com.



201 Northfield Road | Northfield IL 60093 U.S.A. | Tel: 773.478.3515 | Fax: 773.478.3232
info@bodine-electric.com | www.bodine-electric.com