

Instructions for Installation and Operation

Type ABL-3906C Low-Voltage Brushless DC Motor Controls (IP-00)

Model 3908 12 VDC (60° commutation)

Model 3909 24 VDC (60° commutation)

Model 3919 24 VDC (120° commutation)



SPECIFICATIONS

Power Supply Voltage:.....	Model 3908: 12 to 14 VDC Model 3909, 3919: 24 to 35 VDC
Output Current (Continuous):	Model 3908: 20.0 Amps Model 3909, 3919: 18.0 Amps
Peak Current:.....	Model 3908: 30.0 Amps Model 3909, 3919: 27.0 Amps



This manual contains the basic information needed to install and operate the Bodine type ABL-3906C Low-Voltage Brushless DC Motor Control. This manual does not profess to cover all details or variations in equipment, nor to provide for every possible contingency associated with installation, operation, or maintenance. No warranty of fitness for purpose is expressed or implied. Should further information be desired or should particular problems arise which are not covered sufficiently for the user's purpose, the matter should be referred to the Bodine Electric Company.

IMPORTANT

Read this manual completely and carefully. Pay special attention to all warnings, cautions, and safety rules. Failure to follow the instructions could produce safety hazards which could injure personnel or damage the control, motor, or other equipment. If you have any doubts about how to connect the control or motor, refer to the detailed sections of this manual.

QUICK REFERENCE

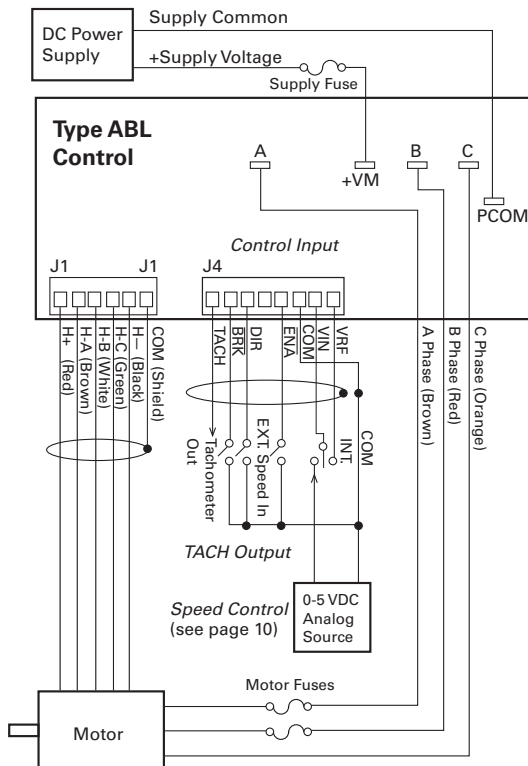

Figure 1 – Quick Reference Connection Diagram

TABLE OF CONTENTS

QUICK REFERENCE	2
PRODUCT SPECIFICATIONS.....	4
IMPORTANT SAFETY PRECAUTIONS.....	5
INSTALLATION	6
ELECTRICAL CONNECTIONS	7
Motor Fuses	8
Motor Phase & Commutation Connections	8
Control Speed Signal Connections	9
Control Logic Connections	10
Tachometer Connection	11
Power Supply Connections	12
Control Fuse	12
OPERATION.....	13
Preliminary Checks	13
Operating the Control	13
Internal Adjustments.....	14
TROUBLESHOOTING.....	16
WARRANTY.....	19

FIGURES

Figure 1 – Quick Reference Connection Diagram	2
Figure 2 – Mounting Dimensions.....	6
Figure 3 – Control Circuit Board Detail.....	7
Figure 4 – Wiring Harness on Bodine Low Voltage Brushless DC Motors	8
Figure 5 – Internal and External Speed Potentiometer Connections	10
Figure 6 – Control Logic Inputs.....	10
Figure 7 – ABL-3906C TACH Output Signal at Three Different Motor Speeds ...	11
Figure 8 – Trim Potentiometer Locations	15

Application Note:

12V brushless DC gearmotors or motors are available as custom or built-to-order models. Standard 24 VDC brushless DC gearmotors and motors can be operated from a 12V control, but performance will not be to nameplate specifications. Please consult the factory for more information. Tel: 773-478-3515 or e-mail to info@bodine-electric.com.

PRODUCT SPECIFICATIONS

The Type ABL-3906C Low-Voltage Brushless DC Motor Control is a chassis type, designed to be mounted in a separate enclosure supplied by the user. It operates from a DC power supply or from a battery (12 VDC or 24 VDC, depending on the control model). The controls provide the necessary electronic commutation and phase current switching to operate Bodine low-voltage brushless DC motors. Speed can be controlled by an external or on-board MAX speed trim potentiometer, or a 0 to 5 VDC analog input signal. Other features include adjustable maximum speed settings, torque, and acceleration and deceleration times. A unique Smart Reverse™ circuit is employed which prevents plug reversing if the user accidentally or intentionally changes the direction signal without bringing the motor to a stop first.

Parameter	Specification
Product Type:	ABL 3906C
Input Voltage:	Model 3908: 12 to 14 VDC Model 3909, 3919: 24 to 35 VDC
Output Voltage:	Model 3908: 0 to 12 VDC Model 3909, 3919: 0 to 24 VDC
Output as % of Input Voltage:	Up to 95%
Max. Input Current (Continuous):	Model 3908: 20.0 Amps DC Model 3909, 3919: 18.0 Amps DC
Max. Output Current (Continuous):	Model 3908: 20.0 Amps Model 3909, 3919: 18.0 Amps
Control Functions:	Dynamic Braking, Direction, Enable
Speed Regulation:	2% at 2500 RPM
Speed Range:	25:1 (100 to 2500 RPM) at rated load and rated supply voltage
Speed Control Method:	External Potentiometer, Analog Voltage, On-Board Potentiometer (MAX Speed trim potentiometer)
Speed Control Scheme:	Pulse Width Modulation (PWM)
PWM Frequency:	20 kHz
Input Levels:	0 to 5 VDC
Acceleration Time:	0.35 to 8.0 seconds
Commutation:	Model 3908, 3909: 60° Standard, TTL compatible Model 3919: 120° Standard, TTL compatible
Ambient Temperature:	0° to 50° C (operating)
Dimensions:	(inches) 5.25 L x 3.25 W x 1.3 H (centimeters) 13.3 L x 8.2 W x 3.3 H
Minimum Enclosure Dimensions	(inches) 12 L x 6 W x 3 H (centimeters) 30.5 L x 15.2 W x 7.6 H

IMPORTANT SAFETY PRECAUTIONS

“The use of electric motors and generators, like that of all other utilization of concentrated power, is potentially hazardous. The degree of hazard can be greatly reduced by proper design, selection, installation, and use, but hazards cannot be completely eliminated. The reduction of hazard is the joint responsibility of the user, the manufacturer of the driven or driving equipment, and the manufacturer of the motor or generator.”*



The Bodine type ABL-3906C control was evaluated by Underwriters Laboratories (UL) for compliance to UL standard 508 and CSA standard C22.2 No. 14. It is a UL recognized component, documented in UL file number E44529, and bears the mark shown above.

Please read through this operations manual in detail and observe those paragraphs with the safety alert symbol.



WARNING

This indicates a potentially hazardous situation which, if not avoided, could result in death or serious injury.



CAUTION

This indicates a potentially hazardous situation which, if not avoided, may result in minor or moderate injury.

CAUTION

This indicates a potentially hazardous situation which, if not avoided, may result in property damage.

RoHS COMPLIANCE

This document certifies that the Bodine Electric type ABL-3906C control is manufactured with materials and processes that comply with European Directive 2002/95/EC on the Restriction of Hazardous Substances (RoHS).

* Standards Publication No. ANSI/NEMA MG-2, “Safety Standard for Construction and Guide for Selection, Installation and Use of Electric Motors and Generators.”

INSTALLATION

Before installation, review the application to confirm that the proper motor and control have been selected. This should be done after reading this manual and all applicable safety standards. If in doubt, contact your Bodine regional sales manager, or the home office if there is no representative in your area. Although Bodine Electric Company assists its customers in selecting motors and controls for specific applications, determination of fitness for purpose or use is solely the customer's responsibility.

⚠ WARNING

This control should only be installed by a qualified technician, electrician, or electrical maintenance person familiar with its operation and associated hazards. The National Electrical Code (NEC), local electrical and safety codes, and when applicable, the Occupational Safety and Health Act (OSHA) should be observed to reduce hazards to personnel and property.

The user must provide a proper enclosure for chassis type controls.

CAUTION

Exposed circuit boards should be protected from electrostatic discharge. The control board uses CMOS circuitry. Static discharge into the control board must be avoided to prevent component damage..

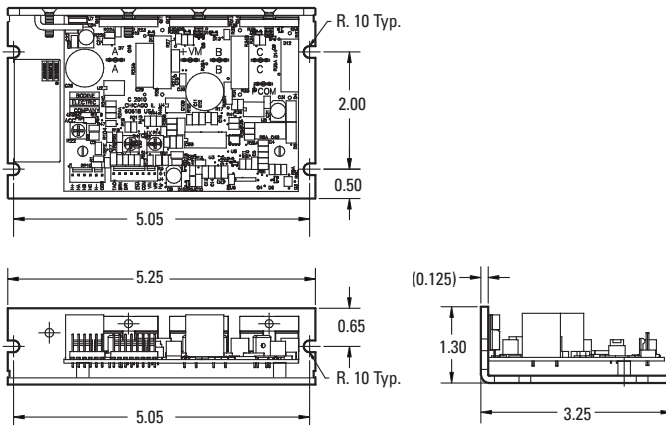

Figure 2 – Use the dimensions shown to locate the mounting holes on the surface where the control is to be located. The control should be mounted vertically, using the slots on either the narrow or wide surfaces of the heat sink. This arrangement provides optimum air flow around the control.

ELECTRICAL CONNECTIONS

Read the following instructions as well as all of the applicable safety recommendations, before making any electrical connections between the control, motor, or other motion control electronics.

⚠ WARNING

The power supply should be the last connection made in order to prevent accidental start-up. Disconnect the power supply before making any other electrical connections.

Figure 3 shows a detailed diagram of the control circuit board and the various connection points. Stock Bodine 24-Volt Brushless DC motors are supplied with commutation leads terminated at connector J1. The motor phase leads are supplied terminated with female quick disconnect terminals.

The control interface leads are the user's responsibility. An 8-pin interface connector J4 and pins are supplied for terminating the interface leads. If the leads supplied on the motor need to be extended, follow the recommendations for wire sizes and maximum lengths listed in this section.

NOTE: The control does not provide motor overload or over temperature protection. The user is responsible for providing this protection in the equipment where this control is used (Remarque: La détection de la surchauffe du moteur n'est pas assurée par cette control).

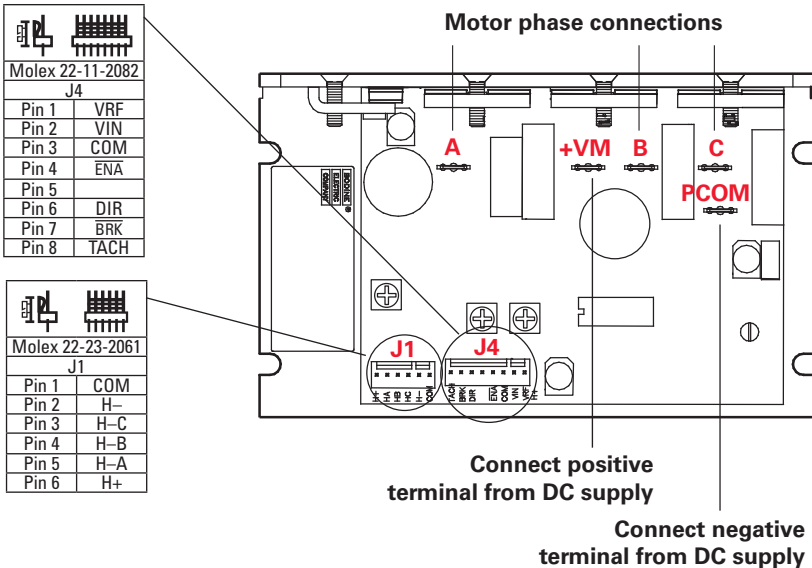

Figure 3 – Control Circuit Board Detail

Control Fuse: The ABL-3906C control should be protected with a fuse in the positive power supply lead. The fuse should be sized to allow the motor to run at full speed and load with a safety margin.

Motor Fuse: The Fuse type should be UL Category JDYX2 with a maximum rating of 25A. The user should install a fuse in two of the three motor phase connections, as shown in Figure 1. The value of the fuse is dependent on the current rating of the motor. Determine the fuse value using the following formula:

$$\text{Motor Fuse Rating} = 1.2 \times \text{Motor Current Rating}$$

Motor Phase Connections: The motor phase outputs which provide power to the motor are labeled A, B, and C on the control board. See Figure 3.

Application Tip:

Because currents in low voltage systems are higher, motor and power supply connections should be kept as short as possible. Wiring should be sized to deliver the nameplate voltage to the control at a minimum. Voltage losses in the wire may have a significant impact on the system’s ability to deliver rated speed and torque.

Connect the phase leads from the motor using the ¼ inch quick disconnect terminals as follows:

- Brown motor wire to control terminal “A”
- Red motor wire to control terminal “B”
- Orange motor wire to control terminal “C”

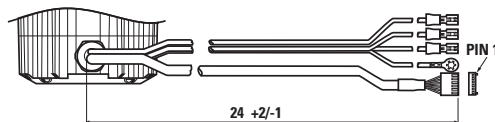

Figure 4 – Wiring Harness on Bodine Low Voltage Brushless DC Motors

Motor Commutation Sensor Connections: Connector J1 is used to connect the commutation sensor leads from the motor to the control board. See Figure 3 for location of J1. Bodine’s standard low voltage Brushless DC motors have the mating connector for J1 at the end of its wiring harness (See Figure 4). Simply mate the polarized connector with the pins on the control board.

Chart 2 - Commutation Sensor Pin Out (Connector J1)

Designation	Description	Lead Color
COM*	Drain Wire Connection	Shield
H-	Commutation Sensor Supply Return	Black
H-C	Commutation Sensor C Input	Green
H-B	Commutation Sensor B Input	White
H-A	Commutation Sensor A Input	Brown
H+	+12V Commutation Sensor Supply	Red

* The COM terminal must not be used as a common for the external power supply.

Control Speed Signal Connections: Motor speed can be controlled in one of three ways:

1. Controlling Speed With an External Potentiometer (included):

An external 10 K Ω potentiometer can be used to externally control motor speed (for applications where more frequent speed changes are required). Clockwise rotation of the potentiometer increases motor speed, when connected as follows:

- a. Solder three leads of appropriate length to the potentiometer.
- b. Terminate the other ends of the potentiometer leads with the pins supplied with the 8-pin interface connector.
- c. Mount the potentiometer in the desired location.
- d. Refer to Figure 5 and insert the potentiometer leads into the interface connector as follows:
 - i. High side (CW terminal) of the potentiometer to interface terminal VRF
 - ii. Low side (CCW terminal) of the potentiometer to interface terminal COM
 - iii. Center terminal of the potentiometer to interface terminal VIN
- e. The MX potentiometer on the control board may be used to limit the maximum motor speed obtainable with the control.

2. Controlling Speed With an Analog Input Voltage: Motor speed can be controlled by with a 0 to 5 VDC analog input signal (for applications where the motor and control are part of a larger control system). Apply the 0-5 VDC signal across the VIN and COM terminals of the interface connector J4. Refer to Figure 5. Speed is increased by increasing the voltage level applied to VIN (Pin J4-2). 0 VDC = 0 RPM; 5 VDC = Max. RPM. This input may be configured for either internal or external speed command operation. If the motor/control system is part of a larger motion control system, the speed may be controlled by a microprocessor or PLC provided a digital to analog converter is used to interface the output of the system control and the speed input of the ABL-3906C control.

3. Controlling Speed with the On-board Trim Potentiometer: Motor speed can be controlled using the on-board MX potentiometer (for applications requiring infrequent adjustment of speed or fixed speed operation). See Figure 8 for the location of the MX potentiometer. In order for the MX potentiometer to function as a speed control, a jumper must be placed across terminals VRF and VIN on the interface connector as indicated by the dashed line in Figure 5. Form a jumper from a short length of wire terminated on each end with the pins supplied with the interface connector. Clockwise rotation of the MX potentiometer increases motor speed.

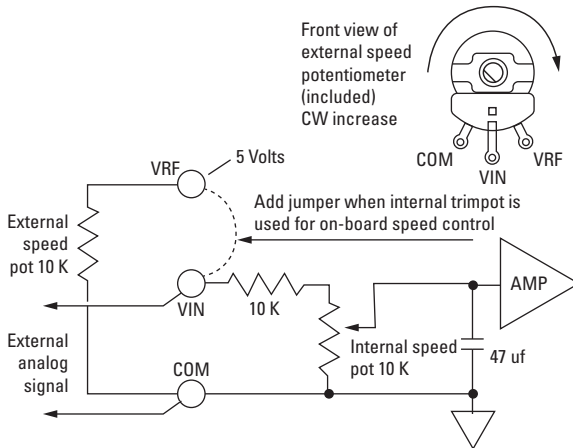

Figure 5 – Internal and External Speed Potentiometer Connections

Control Logic Connections: Manual switches, relays, or logic signals can be used to control motor braking, enable, and direction of rotation. Figure 6 shows the pin-out of the interface connector J4, as well as interface information for the logic inputs. Chart 3 lists the condition of the control input based on the open or closed condition of the relay contact or switch and the high or low state of the input signal.

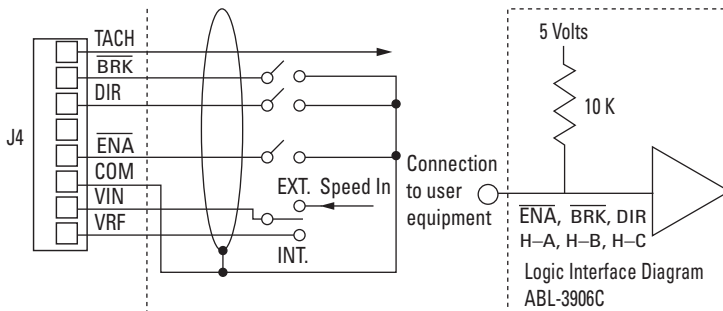

Figure 6 – Control Logic Inputs

⚠ WARNING

Never rely on logic circuitry as a means of disabling the motor or control. To prevent mechanical motion and potential injury, the AC power should always be disconnected from the control power supply whenever logic circuits or the driven equipment are serviced. When a battery is used, the DC supply to the control should be disconnected.

Chart 3 – Pin-Out and Logic State of Control Inputs

Designation	Closed-Switch or Low Voltage State ¹	Open-Switch or High Voltage State ¹
\overline{ENA} ²	Drive Enabled	Drive Disabled
DIR ³	CCW Direction	CW Direction
BRK	Brake	Run

1. Logic Low=0.0-0.4 V; Logic High=3.0-5.0 V
2. When ENA goes high the motor will coast to a stop
3. The output shafts of gearmotors with odd number of stages (for example, Bodine type designations ending with W3, E1, or E3) will rotate in the opposite direction. A “Smart Reverse Circuit” prevents plug reversing if the switch is opened or closed while the motor is running. The motor will coast to low speed before changing direction. However, it is best to stop the motor before changing the DIR input to avoid overspeeds when accelerating back to the set speed.

Tachometer Connection: The ABL-3906C control provides a digital tachometer output at the TACH terminal (J4, Pin 8) for monitoring motor speed. The 5 VDC output pulse levels are low to high to low. The pulse width is fixed at 0.55 msec each. Twelve pulses correspond to one motor revolution. The buffered output requires no external pull-up resistor to produce the 5 VDC pulses. If the user prefers an analog voltage tachometer signal instead of digital pulses, the average voltage from the TACH output is directly proportional to motor speed. An external filter or averaging circuit is needed to read the digital output as an analog 0-5 VDC output.

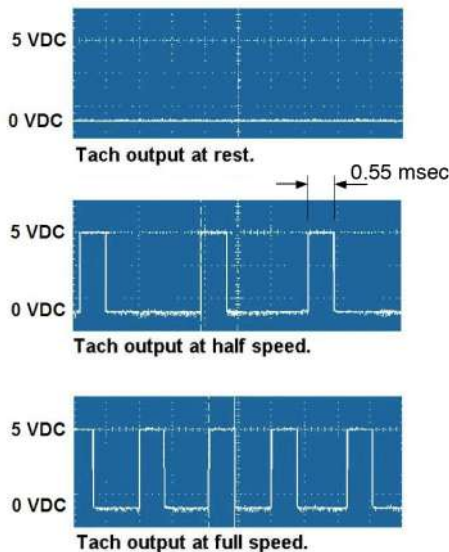

Figure 7 – Snapshots of three scope readouts showing the ABL-3906C TACH output signal at three different motor speeds.

Power Supply Connections: The ABL-3906C control requires either a 12 VDC or a 24 VDC external DC power source (depending on the control model). The power supply must provide a minimum capacitance of 5000 μ fd per control. The supply must provide the required peak and continuous current for the type of control and motor being used. Refer to the Specifications on page 5 to determine the proper current capacity for your specific control. The controls can be powered by a battery (either 12 VDC or 24 VDC, depending on the control model) provided it delivers sufficient current capacity to fulfill the duty cycle requirements of the application. Terminals included.

Application Tip:

Size wires according to the power required in the system. Long lead wires from the power supply will reduce available voltage to the control. The power wiring must deliver rated voltage to the control to allow performance to specified ratings.

Connect the power supply to the control using 1/4 inch quick disconnect terminals as follows:

1. Connect the (+) lead from the power supply to the +VM terminal on the control circuit board.
2. Connect the power supply common to the PCOM terminal on the control circuit board.

CAUTION

The COM terminals on the Commutation Sensor (J1) and Interface Connector (J4) should never be used as the common for the external power supply.

Control Input Fuse Calculation: The control must be protected by a user-supplied UL Recognized JDYX2 fuse with a maximum rating of 25 A. In a multi-control system each control must have a separate fuse. Make sure the fuse is connected in series with the (+) lead of the power supply. See Figure 1. The value of this fuse is dependent on the amount of input current drawn by the control when the motor is operated at full load. Determine the fuse value using the following formula:

Control Input Fuse Rating = 1.25 x (RMS Control input current at full load)

CAUTION

If the calculated rating does not correspond to a standard fuse use the next highest rated fuse.

OPERATING INSTRUCTIONS

WARNING

Explosions, fires, or electric shock hazards can be reduced through thermal and over-current protection, good maintenance, proper grounding, and enclosure selection. Review safety considerations outlined in “Important Safety Precautions”, “Installation”, “Electrical Connections”.

Preliminary Checks

1. Before starting the control, check all fuses, connections, and adjustments.
2. Proper consideration should be given to all rotating members. Before starting, be sure keys, pulleys, etc. are securely fastened. Proper guards should be provided to prevent hazards to personnel while the equipment is rotating.
3. Mechanical considerations such as proper mounting and alignment of products, and safe loads on shafts and gears should be reviewed. Do not depend upon gear friction to hold loads.
4. The motor or gearmotor should be securely mounted (because of possible reaction torque). Test the motor/gearmotor unloaded to be certain that proper connections have been made.
5. If the motor/gearmotor does not start promptly and run smoothly, disconnect the power source to the external DC power supply. Double check all wiring, and refer to “Troubleshooting” on page 16.
6. If the problem persists, contact your Bodine representative or a Bodine Authorized Service Center and describe the problem in detail. Include all the nameplate data. Do not disassemble the product unless authorized by Bodine. Removing screws voids the Warranty.

Operating the Control

WARNING

The power source should be disconnected from the DC power supply before starting.

1. Disconnect the power source to the external power supply. If the power supply has an ON/OFF switch set it to OFF.
2. Set the speed potentiometer to ZERO (fully counterclockwise). If an Enable switch is used, open the switch. If a Brake switch is used, open the switch. Refer to Chart 3.
3. Connect the AC power to the external power supply. If the power supply has an ON/OFF switch, set it to ON. When power is applied to the control, the green “PWR” LED will light.
4. Set the Direction switch, if provided, for the proper direction of rotation. Refer to Chart 3.

5. Close the Enable switch if used.
6. Turn the speed potentiometer clockwise until the motor rotates. Then adjust the potentiometer to achieve the desired speed. If you wish to reduce the torque level refer to “Internal Adjustments” which follows.
7. If the motor does not operate, check all connections and fuses. If a fuse is blown and the motor is not locked (stalled) or overloaded, do not replace the fuse. The control may be damaged. Refer to “Troubleshooting” and follow instructions. If the motor is overloaded, reduce the load and replace blown fuses with a new one of the proper rating.

Internal Adjustments

To adjust the control for your specific application, proceed as follows:

WARNING

Use a non-metallic or insulated adjustment tool for internal adjustments. Circuit components are not at ground potential and accidental short circuiting and shock hazard may occur with conducting tools. Adjustment should be made only by qualified service personnel.

Maximum Speed Trim Potentiometer: When used in conjunction with an external speed potentiometer, the lowest MX trim potentiometer setting (fully counterclockwise) corresponds to zero speed and the highest MX trim potentiometer setting (fully clockwise) corresponds to approximately 120% of rated speed.

When used as an on-board speed potentiometer, the fully counterclockwise position corresponds to 0 RPM and the fully clockwise position corresponds to 2500 RPM (24VDC model); 1250 RPM for a 24VDC motor operated with the 12VDC control.*

* Note: These ratings are based on the assumption that the input signal does not exceed a maximum of 5 Volts.

Scaling the Motor Speed to Correspond to a Given Input Voltage: The MX speed potentiometer can be used to adjust the maximum speed of the motor to correspond to a specific input voltage by performing the following procedure:

1. Apply the desired voltage across terminals VIN (J4-Pin 2) and COM (J4-Pin 3) of the 8-pin interface connector.
2. Adjust the MX potentiometer until the motor RPM reaches the desired level. This adjustment assures that the motor will not exceed the calibrated speed provided the analog input voltage does not exceed the level applied in step 1.

Torque (Current) Limiting Adjustment: The TQ trim potentiometer (Figure 8) has been calibrated so that the control output current limit is 150% of the control's nameplate current rating. That is, the peak current limit of the 12 volt model is factory-set to 30 Amps and the peak current limit of the 24 volt model is factory-set to 27 Amps. In some cases, it may be desirable to reduce the peak current limit to a level less than the factory setting, in order to protect drive mechanisms, such as gearing, from damage due to overloads. Turn the TQ trim potentiometer counterclockwise to decrease the torque and clockwise to increase the torque.

Acceleration Adjustment: Trim potentiometer ACC (See Figure 8) can be used to adjust the motor's acceleration time. A counterclockwise adjustment decreases the acceleration time down to a minimum of approximately 0.35 seconds. A clockwise adjustment increases the rate up to a maximum of approximately 8 seconds.

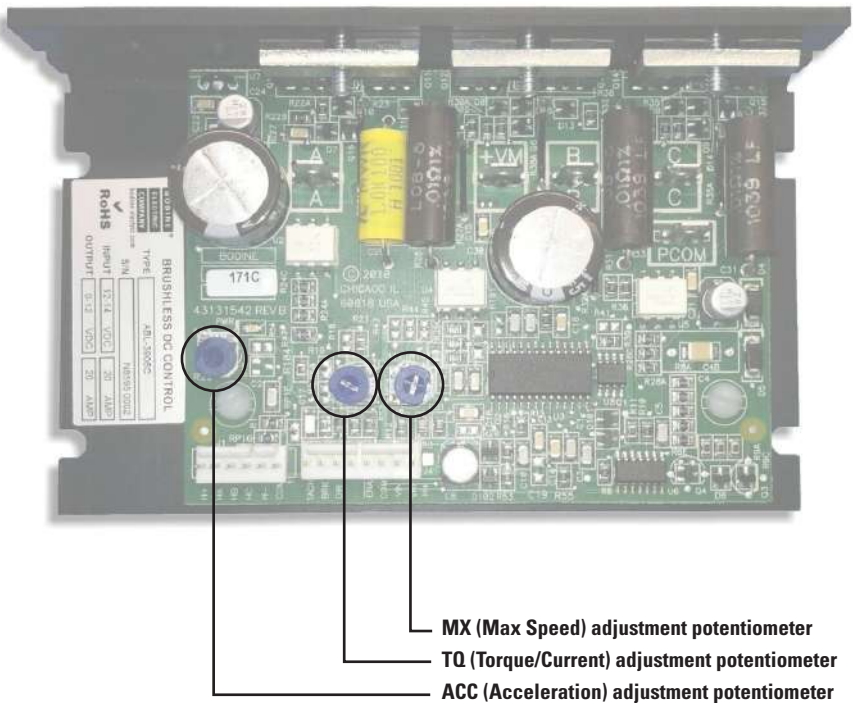

Figure 8 – Trim potentiometer locations

TROUBLESHOOTING

WARNING

Do not attempt to install or remove the electrical connectors when the power supply is turned on. Do not attempt to wire circuitry while power is on.

All Bodine controls undergo extensive testing and calibration procedures to detect and eliminate defects. Your control should not require maintenance under normal conditions. If you encounter a problem, read all instructions and double-check the wiring. Even if the Bodine control is definitely defective, it may be that another defective component in the system caused it to fail, in which case replacing the Bodine control alone and not tending to the root cause of the failure may result in another damaged product. Chart 4 may assist in troubleshooting foreseeable problems which may occur during installation and operation.

If problems persist, contact your source of purchase or a Bodine Authorized Service Center and describe the problem in detail. Do not disassemble the product unless authorized by Bodine Electric Company. Performing unauthorized repairs will void the Warranty.

GENERAL EVALUATION – Knowing the circumstances under which the problem occurred can help to identify the root cause of the problem. The following are two questions you should ask yourself before tearing everything apart:

Has the system ever operated properly? If the system was just installed and hasn't worked right from the beginning, then it is very likely that something wasn't done correctly in the installation. Focus on incorrect wiring or incorrect programming of remote devices. On the other hand, if the system has been working for an extended period of time and just recently stopped working, then this would indicate that the system was initially installed properly but has somehow changed. Focus instead on failed components or deteriorated wiring.

Is the problem continuous or intermittent? If the problem always occurs and never goes away, then it would indicate something inherently wrong in the connections or a defective component. On the other hand, if the system operates properly most of the time and only occasionally does something wrong, then this might indicate loose connections or electrical noise interference.

CHART 4 - General problem evaluation method

SYMPTOM	PROBABLE CAUSE	CORRECTIVE ACTION
Control blows power supply fuse	Incorrect power supply wiring	<ul style="list-style-type: none"> • Check connections. Look for shorts and repair as required.
	Excessive power supply voltage	<ul style="list-style-type: none"> • Check power supply voltage. If voltage exceeds the control rating (see page 4), then replace with a properly rated power supply.
	Voltage transients on the power supply lines	<ul style="list-style-type: none"> • Check for transients. If they are present, shield the power supply lines and add surge suppressors. If problem persists, contact Bodine Electric.
	Shorted phase leads, wiring incorrect	<ul style="list-style-type: none"> • Repair short. Correct wiring.
	Damaged control components	<ul style="list-style-type: none"> • Contact Bodine Electric or a Service Center for assistance.
Motor will not start. "PWR" LED is off.	Open power supply fuse	<ul style="list-style-type: none"> • Replace fuse. Refer to page 12.
	Power supply turned OFF.	<ul style="list-style-type: none"> • Check that power supply is turned ON.
	Faulty power supply	<ul style="list-style-type: none"> • Verify proper operation. Replace if necessary.
Motor will not start. "PWR" LED is on.	Speed potentiometer set to zero (if external or on-board potentiometer is being used)	<ul style="list-style-type: none"> • Increase speed potentiometer setting.
	Speed potentiometer is defective (if external potentiometer is being used)	<ul style="list-style-type: none"> • Check if external speed potentiometer is working properly. Replace if necessary.
	Speed potentiometer is wired incorrectly (if external potentiometer is being used)	<ul style="list-style-type: none"> • Check wiring for external speed potentiometer. Correct if necessary. Refer to Figure 5.
	No jumper wire between VRF and VIN (if on-board potentiometer is being used)	<ul style="list-style-type: none"> • Check for jumper between VRF and VIN. Correct if necessary. Refer to Figure 5.
	No speed signal (if remote analog signal is being used)	<ul style="list-style-type: none"> • Check wiring for remote speed signal. Correct if necessary. Refer to Figure 5.
		<ul style="list-style-type: none"> • Check that remote source is actually sending a speed command (0-5 VDC). Correct if necessary.
	Brake (BRK) switch closed	<ul style="list-style-type: none"> • Open BRK switch, if there is one.
	Enable (ENA) switch open	<ul style="list-style-type: none"> • Close ENA switch (there must be one)
	Incorrect commutation angle	<ul style="list-style-type: none"> • Check that commutation angle of the motor and control match. Stock motors with 120° commutation angle have a blue marker on the commutation cable.
	Incorrect motor phase connections	<ul style="list-style-type: none"> • Check motor phase connections. Correct if necessary. Refer to Figure 1.
	Loose commutation sensor connector J1	<ul style="list-style-type: none"> • Check that connector is securely fastened to control header. Correct if necessary. Refer to Figure 3.
	Torque (TQ) pot set too low	<ul style="list-style-type: none"> • Adjust TQ pot. Refer to page 15.
	Motor is overloaded	<ul style="list-style-type: none"> • Reduce load or replace motor with a stronger model
	Damaged motor	<ul style="list-style-type: none"> • Repair or replace motor.

Motor runs, but at full speed only and can't be adjusted	Open speed signal connection	<ul style="list-style-type: none"> • Make sure there is a connection at VIN, whether it is an external encoder or a remote analog signal. Correct if necessary. Refer to Figure 5.
	Defective speed potentiometer (if an external potentiometer is used)	<ul style="list-style-type: none"> • Replace the external speed potentiometer.
	Jumper mistakenly placed across VRF and VIN (if an external speed pot or analog signal is used)	<ul style="list-style-type: none"> • Remove jumper across VRF and VIN. Refer to Figure 5.
Motor runs, but won't come up to desired speed	Maximum (MX) speed limit potentiometer set too low	<ul style="list-style-type: none"> • Adjust MX potentiometer if necessary. Refer to page 14.
	Speed signal set too low	<ul style="list-style-type: none"> • Increase speed setting. Depending on the method used, either adjust the external speed pot, or increase the remote analog voltage, or adjust the MX pot. Refer to page 9.
	Torque (TQ) pot set too low	<ul style="list-style-type: none"> • Adjust TQ pot. Refer to page 15.
	Motor is overloaded	<ul style="list-style-type: none"> • Reduce load or replace motor with a stronger model
	Incorrectly sized power supply	<ul style="list-style-type: none"> • Replace power supply with a unit having sufficient voltage and current capacity to provide rated voltage under full load
Motor runs, but speed is unstable at any speed	Motor and load not correctly aligned	<ul style="list-style-type: none"> • Correct mechanical alignment if necessary.
Motor runs, but speed is unstable or pulsates at low speeds	Speed setting is too low	<ul style="list-style-type: none"> • Increase speed setting. Depending on the method used, either adjust the external speed pot, or increase the remote analog voltage, or adjust the MX pot. Refer to page 9.
		<ul style="list-style-type: none"> • Replace motor with a model having a higher gear ratio
Motor runs, but won't maintain speed under increased load	Torque (TQ) pot set too low	<ul style="list-style-type: none"> • Adjust TQ pot. Refer to page 15.
	Incorrectly sized power supply	<ul style="list-style-type: none"> • Replace power supply with unit having sufficient voltage and current capacity to provide rated voltage under full load
	Motor is overloaded	<ul style="list-style-type: none"> • Reduce load or replace motor with a stronger model

BODINE LIMITED WARRANTY

The Bodine Electric Company warrants all products it manufactures to be free of defects in workmanship and materials when used under Normal Operating Conditions and when applied in accordance with nameplate specifications. When Bodine motors and gearmotors have been purchased with and used only with appropriately applied Bodine controls, this warranty shall be in effect for a period of twenty-four months from date of purchase or thirty months from date of manufacture, whichever comes first. Bodine motors and gearmotors used with non-Bodine controls and Bodine controls used with non-Bodine motors and gearmotors are covered by a standard twelve-month warranty period.

The Bodine Electric Company will repair, replace, or refund at its option, any of its products, which has been found to be defective and is within the warranty period, provided that the product is shipped freight prepaid, with previous authorization, to Bodine Electric, or to the nearest Bodine Authorized Service Center. At its option, all return shipments are F.O.B. Bodine's plant or Authorized Service Center. Bodine is not responsible for removal, installation, or any other incidental expenses incurred in shipping the products to or from Bodine.

This warranty is in lieu of any other expressed or implied warranty - including (but not limited to) any implied warranties of merchantability and/or fitness for a particular use or purpose.

Bodine's liability under this warranty shall be solely limited to repair or replacement of the Bodine product within the warranty period and Bodine shall not be liable, under any circumstances, for any consequential, incidental or indirect damages or expenses associated with the warranted products. Commutator and/or brush wear and its associated effects are normal occurrence and are not covered by this warranty unless otherwise agreed to by Bodine in writing.

Proof of purchase of motor or gearmotor and matching control as a system must be provided with any claim.

Control Type: _____ **Serial No.** _____

Date of Purchase: _____ **Place of Purchase:** _____

Bodine offers over 1,400 standard garmotors, motors and system-matched speed controls.



**Visit www.bodine-electric.com
for our large selection of 24 VDC (& 12 VDC)
brushless DC motors and gearmotors**

Bodine offers the widest selection of variable-speed AC, permanent magnet DC and brushless DC fractional horsepower gearmotors and motors in the industry. For complete specifications, 3D CAD drawings, or to order online, visit bodine-electric.com.

