

Instructions for Installation and Operation

Type WPM Filtered PWM Speed Controls for Permanent Magnet DC Brush Motors

- Models 0780 & 0781 with quick connect tabs
- Models 0783 & 0784 with plug-in terminal block

SPECIFICATIONS

Input Voltage	115 VAC ±10%, 50/60 Hz, single phase
Max. Input Current, Continuous	
Models 0780 & 0783	2.5 Amps RMS
Models 0781 & 0784	5.7 Amps RMS
Drive Type	PWM
Output Voltage	Adjustable, 0-130 VDC
Max. Output Current, Continuous	
Models 0780 & 0783	2.00 Amps DC*
Models 0781 & 0784	3.20 Amps DC
Max. Output Current, Peak	
Models 0780 & 0783	2.20 Amps DC
Models 0781 & 0784	5.00 Amps DC
Motor Type	Permanent Magnet Brush DC
Ambient Temperature	0-50°C (32-122°F)
Speed Regulation Adjustment	1% of rated speed obtainable with most DC motors
Acceleration/Deceleration Time	Adjustable, 0.1-15 seconds
Means for Speed Adjustment	10K Ohm pot or isolated 0-5 VDC signal
Means for Drive Inhibit	switch closure
Diagnostics	green power LED, red current limit LED

* Thermal rating only. Actual max. continuous output current is 1.25 Amps.

INSTALLATION

WARNING: This control should only be installed by a qualified person familiar with its operation and associated hazards. The National Electrical Code (NEC), local electrical and safety codes, and when applicable, the Occupational Safety and Health Act (OSHA) should be observed to reduce hazards to personnel and property.

NOTE: The control does not provide motor over temperature protection. The user is responsible for providing this protection in the equipment where this control is used (Remarque: La détection de la surchauffe du moteur n'est pas assurée par cette control).

Step 1: Mounting the Control

The control may be mounted with the plane of the circuit board either horizontal or vertical. The four mounting slots will accommodate #8 screws.

CAUTION—Exposed circuit boards must be protected from electrostatic discharge during handling to prevent component damage.

CAUTION—Mount the control chassis in an enclosure suitable for the application environment.

Step 2: Preliminary Setup

MOTOR SIZE SELECTOR SWITCHES—Figure 1 shows the location of a bank of 8 DIP switches. Set switches 1 through 6 to match the type, speed, and current ratings on the Bodine motor nameplate per Figure 2 (Consult Bodine on settings for non-Bodine motors).

ACCEL / DECEL SELECTOR SWITCHES—Figure 4 (see next page) shows the location of a bank of 8 DIP switches. Set switches 7 and 8 to select the acceleration/ deceleration time range per Figure 3.

Step 3: Electrical Connections

WARNING—All parts of the circuit operate at voltages capable of causing serious injury or death. Wait 7 minutes after disconnecting control from AC power before handling it.

WARNING—AC power should be the very last connection.

INHIBIT SWITCH (OPTIONAL)—A mechanical switch or relay with low voltage contacts may be connected to terminals "H1" and "H2". The motor will stop when the switch is closed.

WARNING—The inhibit switch should not be used to disable motor or control when servicing these or driven equipment. Disconnect AC power instead.

FIGURE 1—Control mounting dimensions

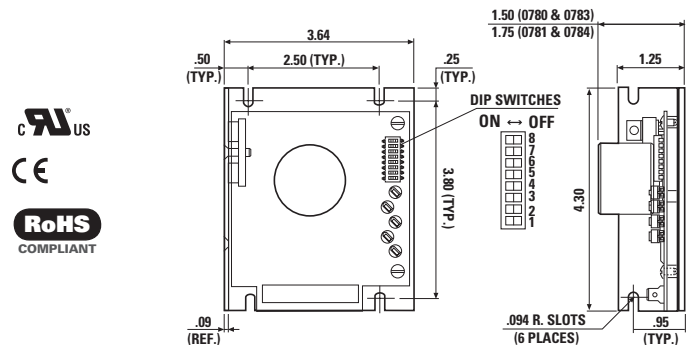

FIGURE 2—Setup of Dip Switches 1 through 6

Control	Motor Ratings			Control Setup			
	Motor Type	Armature RPM@ 130V ¹	Motor Rated Amps ²	Motor HP	Dip Switches On	Peak Output Amps ³	Continuous Input Current ⁴
0780 & 0783	24A0	2500	0.22	1/50	Consult Bodine Factory		
	24A2	2500	0.3	1/29	1,2	0.6	0.8
	24A4	2500	0.48	1/17	1,2,3	1.0	1.1
	24A4	2500	.56 .81	1/23 1/11	3,5,6	1.2	1.4
	33A3	2500	.78 1.0	1/16 1/8	2,4,5,6	2.1	1.9
	33A3	2500	0.74	1/12	3,5,6	1.2	1.4
	33A3	2000	0.71	1/12	3,5,6	1.2	1.2
	33A5	2500	0.91	1/8	2,4,5,6	2.1	1.9
	42A3	2500	1	1/8	2,4,5,6	2.0	2.0
	42A4	2000	1.3	1/6	1,2,4,5,6	2.2	2.5
0781 & 0784	24A4	11500	1.1	1/7	3 ⁵	1.7	1.9
	33A3	2500	0.74	1/12	1	1	1.4
	33A3	2500	.78 1.0	1/16 1/8	3	1.7	1.9
	33A3	2000	0.71	1/12	1	1	1.4
	33A5	2500	1.4(1.3) 1.8(1.7)	1/8 1/4	2,3	2.0	2.5
	33A5	2000	1.4	1/6	3	1.7	1.9
	33A5	2500	0.91	1/8	3	1.7	1.9
	33A7	2500	1.8 2.4	1/6 1/3	3,5	4.1	3.6 4.8
	42A3	2500	1	1/8	1,3	1.9	2
	42A4	2000	1.3	1/6	2,3	2	2.5
	42A5	2500	1.9 1.8	3/16 1/4	3	1.7	1.9
	42A5	2500	1.8	1/4	3,5	4.1	3.6
	42A5	2500	2.7	1/3	3,5	4.1	4.8
	42A7	2500	2.3	1/3	2,3,5	4.9	4.0
42A7	2500	3.4	1/2	2,3,5	5.0	5.7	
42A7	2500	3.3	7/16	2,3,5	5.0	5.7	

FIGURE 3—Setup of dip switches 7 and 8

Switches	Acceleration/Deceleration Time Range (seconds) ⁶		
	7	8	ACC pot fully CCW (factory setting)
Off	Off	0.1	0.3
Off	On	0.5	2.0
On	Off	3.5	12.0
On	On	4.0	15.0

1. For armature speed of a geared motor, multiply the output speed at the driveshaft by the gear ratio.
2. If the user desires to install their own armature fuse on the control output to protect the motor from continuous overloads, base fuse ratings on the motor rating in this column.
3. Peak current available with TORQ pot in fully CW position (factory setting). This current exceeds the continuous rating of the motor and is for intermittent overload conditions only.
4. Use this column for sizing a line fuse on the control input.
5. The REG potentiometer must be turned fully CCW (off) for high-speed type 24ABEPM motor.
6. Time for voltage across A1 and A2 to ramp up to 130 V when speed pot is turned from 0 to 100; or to ramp down to 0 V when it is turned from 100 to 0. The time for a motor to accelerate from 0 to 2500 rpm or decelerate from 2500 to 0 rpm is dependent on motor size and loading conditions.

INSTALLATION, continued

CAUTION—The control board signal common is not at ground potential. Any external signal or equipment connected to the control must be electrically isolated from ground.

SPEED POTENTIOMETER—Connect a 10K Ohm potentiometer (included with control) to terminals “S1”, “S2”, and “S3” as shown in **Figure 4**. Alternatively, an isolated 0–5 VDC signal may be connected to “S2” using “S1” as common.

Wiring the Speed Pot—Turn the wiper to the full CW position and measure the resistance between the center terminal and the end terminals. Connect the end terminal that measures 0 Ohms to “S3” (+). Connect the other end terminal to “S1”. Motor speed will increase with CW pot rotation.

MOTOR—For clockwise armature rotation, connect the “+” motor wire (white on Bodine motors) to terminal “A2” and the “–” motor wire (black on Bodine motors) to terminal “A1”. To reverse rotation, reverse the motor connection.

LINE FUSE—Connect a fuse (not included with control) between “L1” and the “hot” side of the AC line. Use information in **Figure 2**, along with applicable safety standards and the assistance of a fuse supplier, to select a proper fuse value.

AC POWER—Connect the AC line to “L2” and the fuse connected to “L1”.

FIGURE 4—Electrical connections and internal adjustments

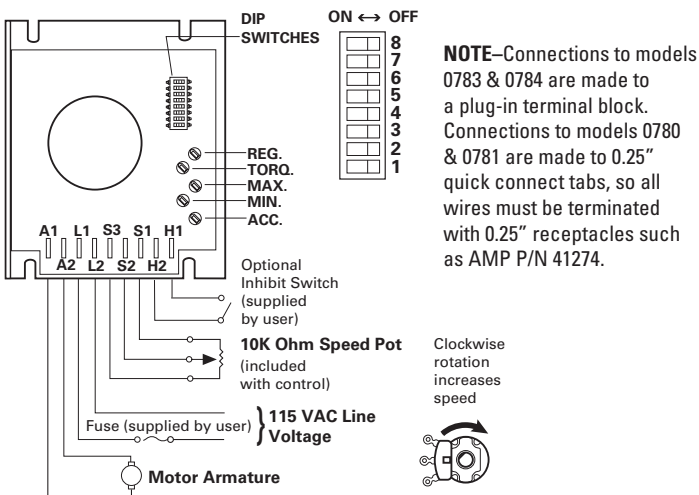

TROUBLESHOOTING

WARNING—Disconnect the control from the AC power source and wait 7 minutes before servicing.

If the motor does not operate, observe the two diagnostic LEDs.

1. If green “PWR” LED is not illuminated, control is not getting power from AC line. Turn power off and double check all connections and fuses.
2. If both the green “PWR” LED and the red “LMT” LED are illuminated, make sure the TORQ pot is not turned fully counterclockwise. If the motor is overloaded, reduce the load or use a larger motor.
3. If a fuse is blown and the motor is overloaded, reduce the load and replace the fuse with a new one of the same type and rating.
4. If a fuse is blown and the motor is not locked (stalled) or overloaded, do not replace the fuse. The control may be damaged.
5. If problem persists, contact a Bodine Authorized Service Center and describe the problem. Include nameplate data for both motor and control.

OPERATION

Step 4: Preliminary Checks Before Starting

1. Recheck all fuses, connections, and adjustments.
2. Check that the gearmotor is securely mounted.
3. Test the motor unloaded first (follow instructions in Step 5). If the motor operates properly unloaded, then proceed with testing it loaded.
4. Check all rotating members. Be sure keys, pulleys, etc. are securely fastened and safety guards are in place.
5. Check for proper mounting and alignment of products, and verify safe loading on shafts and gears.

Step 5: Operating the Control

1. With AC power OFF, set the speed pot to “0”.
2. Turn AC power ON. If an inhibit switch is used, open it.
3. Turn speed pot until motor rotates at desired speed. Note that “SCR rated” motors (rated 90 VDC) can run faster with a WPM control because of the 130 VDC max. output voltage.
4. If motor doesn’t start and run smoothly, refer to “TROUBLESHOOTING”.

Step 6: Trim Pot Adjustments

To fine tune the control, use the five trim pots, shown in **Figure 4**.

WARNING—Circuit components are at high potential and accidental short-circuiting and shock hazard may occur with conductive tools. Use a non-metallic or insulated adjustment tool for trim pot adjustments.

BODINE LIMITED WARRANTY

The Bodine Electric Company warrants all products it manufactures to be free of defects in workmanship and materials when used under Normal Operating Conditions and when applied in accordance with nameplate specifications. When Bodine motors and gearmotors have been purchased with and used only with appropriately applied Bodine controls, this warranty shall be in effect for a period of twenty-four months from date of purchase or thirty months from date of manufacture, whichever comes first. Bodine motors and gearmotors used with non-Bodine controls and Bodine controls used with non-Bodine motors and gearmotors are covered by a standard twelve-month warranty period. The Bodine Electric Company will repair, replace, or refund at its option, any of its products, which has been found to be defective and is within the warranty period, provided that the product is shipped freight prepaid, with previous authorization, to Bodine Electric, or to the nearest Bodine Authorized Service Center. At its option, all return shipments are F.O.B. Bodine’s plant or Authorized Service Center. Bodine is not responsible for removal, installation, or any other incidental expenses incurred in shipping the products to or from Bodine. This warranty is in lieu of any other expressed or implied warranty – including (but not limited to) any implied warranties of merchantability and/or fitness for a particular use or purpose. Bodine’s liability under this warranty shall be solely limited to repair or replacement of the Bodine product within the warranty period and Bodine shall not be liable, under any circumstances, for any consequential, incidental or indirect damages or expenses associated with the warranted products. Commutator and/or brush wear and its associated effects are normal occurrence and are not covered by this warranty unless otherwise agreed to by Bodine in writing. Proof of purchase of motor or gearmotor and matching control as a system must be provided with any claim.

© Copyright 2024 Bodine Electric Company. Data subject to change without notice.