

# Instructions for Installation and Operation

Type WPM Filtered PWM Speed Controls for Low Voltage PMDC Brush Motors

- 12 Volt: Model 0786 (quick connect) and Model 0787 (terminal block)
- 24 Volt: Model 0788 (quick connect) and Model 0789 (terminal block)

## SPECIFICATIONS

### Input Voltage

12 Volt models	12-14 VDC
24 Volt models	24-35 VDC

(This is the operational range – the input voltage must be at least the rated voltage of the motor to run at rated speed):

### Max. Input/Output Current, Continuous

Model 0786	17 (Amps DC)
Model 0787	15 (Amps DC)
Model 0788	14 (Amps DC)
Model 0789	14 (Amps DC)

### Drive Type

PWM

### Output Voltage

Adjustable 0-12 or 0-24 VDC, up to 95% of input

### Max. Output Current, Peak

35 Amps

### Motor Type

Permanent Magnet Brush DC

### Operating Temperature

0-50°C (32-122°F).

### Speed Regulation Adjustment

1% of rated speed obtainable with most DC motors

### Acceleration/Deceleration Time

Adjustable, 0.1-15 seconds

### Means for Speed Adjustment

10k Ohm pot or 0-5 VDC signal

### Means for Drive Inhibit

switch closure

### Diagnostics

green power LED, red current limit LED

FIGURE 1—Control mounting dimensions

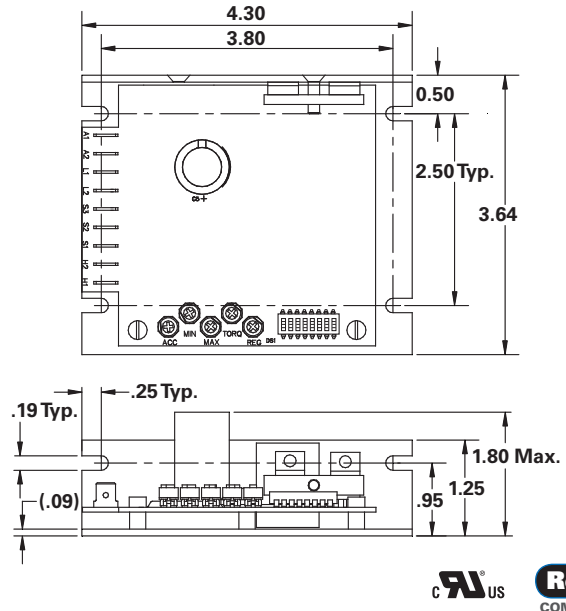

## INSTALLATION

Thank you for purchasing this product. Please read the whole manual before installing and connecting this control.

**WARNING:** This control should only be installed by a qualified person familiar with its operation and associated hazards. The National Electrical Code (NEC), local electrical and safety codes, and when applicable, the Occupational Safety and Health Act (OSHA) should be observed to reduce hazards to personnel and property.

Note: Motor over temperature sensing is not provided by this control.

### Step 1: Mounting the Control

The control may be mounted with the plane of the circuit board either horizontal or vertical. The mounting slots will accommodate #8 screws.

**CAUTION**—Exposed circuit boards must be protected from electrostatic discharge during handling to prevent component damage.

**CAUTION**—Mount the control chassis in an enclosure suitable for the application environment.

### Step 2: Electrical Connections

**WARNING**—The power supply should be the very last connection made.

**INHIBIT SWITCH (OPTIONAL)**—A mechanical switch or relay with low voltage contacts may be connected to terminals “H1” and “H2”. The motor will stop when the switch is closed. Depending on the control settings, some motion is possible at power up even with the inhibit input active.

**WARNING**—The inhibit switch should not be used to disable motor or control when servicing these or driven equipment. Disconnect the power supply instead.

**SPEED POTENTIOMETER**—Connect a 10K Ohm potentiometer (included with control) to terminals “S1”, “S2”, and “S3” as shown in Figure 2. Alternatively, a 0-5 VDC signal may be connected to “S2” using “S1” as common.

FIGURE 2—Electrical connections and internal adjustments

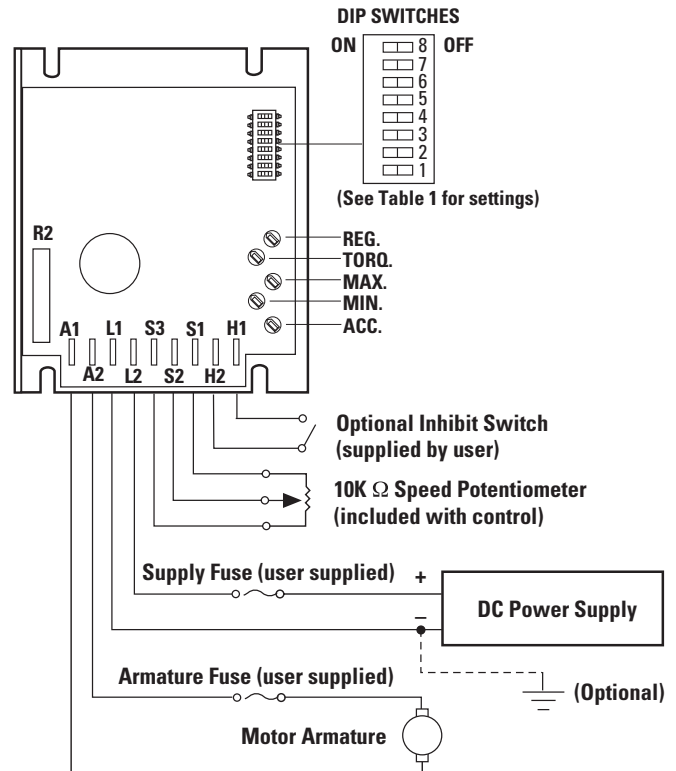

**APPLICATION NOTE:** To measure motor current—connect a voltmeter to R2 and run the motor at desired load. To calculate current (Amps), multiply the result by 100. Example: 0.10V x 100=10 Amps.

# INSTALLATION, continued

**Table 1**—Reference for Current Limit Settings and Fuses

Bodine Motor/Gearmotor Type	Rated Volts	Rated Amps	DIP Switches On	Torque Pot Recommended Setting	Estimated Peak Current at this setting (A)	
24A0	24	1.2	4, 8	2 o'clock	2	
24A2	24	1.8		4 o'clock	3	
24A4	24	2.6	3, 8	4 o'clock	3	
	24	3.7		4 o'clock	7	
	24	4.1		4 o'clock	7	
	12	6.9		4 o'clock	10	
33A3	24	3.7	2, 5, 8	10 o'clock	7.5	
		5.5		10 o'clock	7.5	
33A5	24	5.3		10 o'clock	7.5	
	24	9.2		12 o'clock	15	
33A7	24	12		1 o'clock	19	
		12		2 o'clock	22.5	
42A3	24	5.8		1, 5, 8	10 o'clock	12
42A5	24	8.8			11 o'clock	18
	24	15	1 o'clock		30	
	12 / 24	17	1 o'clock		30	
42A7	24	12	12 o'clock		24	
		15	1 o'clock		30	
		18	2 o'clock		35	
		19	2 o'clock		35	

Note: standard 24 VDC PMDC gearmotors and motors can be operated from a 12V control, but performance may not be to nameplate specifications. Please consult the factory for more information.

**Wiring the Speed Pot**—Turn the wiper to the full CW position and measure the resistance between the center terminal and the end terminals. Connect the end terminal that measures 0 Ohms to “S3” (+). Connect the other end terminal to “S1”. Motor speed will increase with CW pot rotation.

**MOTOR FUSE** – Connect a slow-blow fuse (not included with the control) to the “A2” terminal on the control. Use information in **Table 1**, along with applicable safety standards and the assistance of a fuse supplier, to select a proper fuse value. The rating of the motor fuse should be 1.25 times the motor’s rated amps.

**MOTOR** – For clockwise armature rotation, connect the “+” motor wire (white on Bodine motors) to the motor fuse connected to terminal “A2” and the “-” motor wire (black on Bodine motors) to terminal “A1”. To reverse rotation, reverse the motor connections.

**POWER FUSE** – Connect a fast-acting fuse (not included with the control) between “L2” and the “+” side of the DC power supply. The rating of the line fuse should be 1.25X the maximum continuous input current for the controller.

**POWER SUPPLY** – Connect the positive terminal to the power fuse, then from the power fuse connect to “L2”. Connect the negative terminal to “L1”.

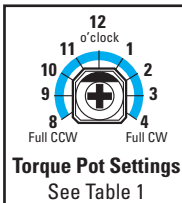

**Torque Limit**—This adjustment limits the control output current, which in turn, limits the available torque from the motor. The factory setting for the peak current limit is determined by the pot position and DIP switch settings as shown in **Table 1**.

The torque is set between 120% and 200% of the current ratings for the largest motor within the dip switch settings group. The limit should be turned down for smaller motors. Bodine generally recommends that the peak current be limited to no more than 200% of the rated current of the motor. Turn the TORQ pot counterclockwise (CCW) to reduce the peak torque capability of the motor. Measure the current through either one of the motor wires while the motor is under load and at full speed. If the current can’t be measured, and an exact adjustment isn’t critical, then the pot might be adjusted by a percentage of the full travel using a visual reference only. For example, if a current limit of half the factory setting is desired, turn the pot CCW to the halfway point between the factory setting and the fully CCW point.

**ACCELERATION & DECELERATION TIME**—The ACC pot adjusts the response time for the control changing the output voltage in response to a change in the speed setting. Turn CW to increase the time. With this pot set fully CW, when the speed signal is switched instantly from 0 to full speed or from full speed to 0, it will take approximately the time indicated in **Table 2** for the output voltage to ramp up from 0 VDC to full output voltage, or down from full output voltage to 0 VDC. Note that this is not necessarily the same time that it will take the motor to ramp up from 0 RPM to full speed, or down from full speed to 0 RPM, because of inertia and friction effects. DIP switches 7 and 8 determine the maximum time range for the ACC pot. See **Table 2**. Factory setting is highlighted.

**Table 2**—DIP Switch 7 and 8 Settings

DIP Switch Setting		ACC pot Max. Time Range (seconds)
7	8	
Off	Off	0.3
Off	On	2
On	Off	12
On	On	14

**SPEED REGULATION**—The REG pot sets the gain of the IR compensation. It is factory-set to provide stable operation with larger motors. Operation with smaller motors will be stable, but the gain might not be high enough to prevent objectionable changes in speed between no load and full load operation. Confirm that the DIP switches are set for the motor/gearmotor per **Table 1**. Then adjust regulation to achieve a full load speed 25-50 RPM below the no load speed at the maximum operating speed for the system. Stability can be judged by either measuring motor speed, or by listening for surging in the motor. If surging occurs, reduce the regulation by turning the REG pot CCW until the surging stops.

## TROUBLESHOOTING

If the motor does not operate, observe the two diagnostic LEDs.

1. If the green “PWR” LED is not illuminated, the control is not getting power from DC power supply. Turn the power off and double check all connections and fuses.
2. If both the green “PWR” LED and the red “LMT” LED are illuminated, make sure the TORQ pot is not too far CCW. If the motor is overloaded, reduce the load or use a larger motor.
3. Check that REG pot and DIP switches are set correctly (see the **SPEED REGULATION** section above).
4. If a fuse is blown and the motor is overloaded, reduce the load and replace the fuse with a new one of the same type and rating.
5. If a fuse is blown and the motor is not locked (stalled) or overloaded, the control may be damaged.
6. If problem persists, contact a Bodine Authorized Service Center and describe the problem. Include nameplate data for both motor and control.

**WARNING**—Disconnect the control from the power source and ensure the power supply voltage is at 0V before servicing the system.

### BODINE LIMITED WARRANTY

The Bodine Electric Company warrants all products it manufactures to be free of defects in workmanship and materials when applied in accordance with nameplate specifications. Bodine motors and gearmotors purchased with and used only with appropriately applied Bodine controls are covered by this warranty for a period of 24 months from the date of purchase or 30 months from date of manufacture, whichever comes first. Bodine motors and gearmotors used with non-Bodine controls and Bodine controls used with non-Bodine motors and gearmotors are covered by a 12 month warranty period. The Bodine Electric Company will repair, replace, or refund at its option, any of its products which has been found to be defective and within the warranty period, provided that the product is shipped freight prepaid, with previous authorization, to Bodine or to a Bodine Authorized Service Center. Bodine is not responsible for removal, installation, or any other incidental expenses incurred in shipping the products to or from Bodine. This warranty is in lieu of any other expressed or implied warranty—including, but not limited to, any implied warranties of merchantability and/or fitness for a particular use. Bodine’s liability under this warranty shall be limited to repair or replacement of the Bodine product and Bodine shall not be liable, under any circumstances, for any consequential, incidental or indirect damages or expenses associated with the warranted products. Proof of purchase of motor or gearmotor and matching control as a system must be provided with any claim.

© Copyright 2017 Bodine Electric Company. Data subject to change without notice.

## OPERATION

### Step 3: Preliminary Checks

1. Recheck all fuses, connections, and adjustments.
2. Check that motor is securely mounted.
3. Check all rotating members. Be sure keys, pulleys, etc. are securely fastened and safety guards are in place.
4. Check for proper mounting and alignment of products, and verify safe loading on shafts and gears.

### Step 4: Operating the Control

1. With the power supply OFF, set the speed pot to “0”.
2. Set DIP switches for the motor/gearmotor per **Table 1**.
3. Turn the power supply ON. If an inhibit switch is used, open it.
4. Turn the speed pot until the motor rotates at the desired speed.
5. If the motor doesn’t start and run smoothly, refer to “TROUBLESHOOTING” section.

### Step 5: Trim Pot Adjustments

To fine tune the control, use the five trim pots, shown in **Figure 2**.

**MINIMUM SPEED LIMIT**—Turn MIN pot clockwise (CW) to make the motor run faster than 0 rpm when the speed pot is set at “0”. With the MIN pot fully CW and the speed pot set at “0”, the motor will run at about 40% of rated speed. Increasing the minimum speed will also increase the maximum speed, so the MAX pot may need to be adjusted.

**MAXIMUM SPEED LIMIT**—Turn the MAX pot counterclockwise (CCW) to make the motor run slower than full speed when the speed pot is set for full speed (5V at S2). With the MAX pot fully CCW and the speed pot set for full speed, the motor will run at about 60% of rated speed.